

**INSTRUCTION
MANUAL XRAY**

XRAY

1/8 LUXURY OFF-ROAD BUGGY



MADE IN
EUROPE

Juraj Hudý
**DEVELOPED
DESIGNED
STYLED BY**
JURAJ HUDÝ
CHIEF XRAY DESIGNER

XRAY

WORLD CHAMPIONS

INTRODUCTION

The XRAY XB9 is a modern, high-competition premium luxury racing 1/8 nitro buggy that is the epitome of high-performance and fine distinctive design. Your XB9 offers highest performance, responsive handling, and traditionally exceptional XRAY quality, engineering, and design. The superb craftsmanship and attention to detail are clearly evident everywhere on the XRAY XB9.

XB9 was designed around a no compromise platform; the attention to detail creates a low maintenance, extra long life nitro buggy. The ultra-low center of gravity (CG) and optimized weight balance makes set-up, driving, and maintenance easy and quick.

CUSTOMER SUPPORT

We have made every effort to make these instructions as easy to understand as possible. However, if you have any difficulties, problems, or questions, please do not hesitate to contact the XRAY support team at info@teamxray.com. Also, please visit our Web site at www.teamxray.com to find the latest updates, set-up information, option parts, and many other goodies. We pride ourselves on taking excellent care of our customers.

You can join thousands of XRAY fans and enthusiasts in our online community at:

www.teamxray.com

The XRAY XB9 was created by blending highest-quality materials and excellent design. On high-speed flat tracks or bumpy tracks, whether driving for fun or racing to win, the XB9 delivers outstanding performance, speed, and precision handling.

We have made every effort to make these instructions as easy to understand as possible. However, if you have any difficulties, problems, or questions, please do not hesitate to contact the XRAY support team at info@teamxray.com. Also, please visit our web site at www.teamxray.com to find the latest updates, set-up information, option parts, and many other goodies. We pride ourselves on taking excellent care of our customers.

XRAY Europe

K Výstavišku 6992
91101 Trenčín
Slovakia, EUROPE
Phone: +421-32-7401100
Fax: +421-32-7401109
Email: info@teamxray.com

XRAY USA

RCAmerica, 2970 Blystone Lane, Suite 109
Dallas, Texas 75220
USA
Phone: (800) 519-7221 * (214) 744-2400
Fax: (214) 744-2401
Email: xray@rcamerica.com

Failure to follow these instructions will be considered as abuse and/or neglect.

SAFETY PRECAUTIONS

WARNING: This product contains a chemical known to the state of California to cause cancer and birth defects or other reproductive harm.

CAUTION: CANCER HAZARD

Wash thoroughly after using. **DO NOT** use product while eating, drinking or using tobacco products. May cause chronic effects to gastrointestinal tract, CNS, kidneys, and blood. **MAY CAUSE BIRTH DEFECTS.**

When building, using and/or operating this model always wear protective glasses and gloves.

Take appropriate safety precautions prior to operating this model. You are responsible for this model's assembly and safe operation! Please read the instruction manual before building and operating this model and follow all safety precautions. Always keep the instruction manual at hand for quick reference, even after completing the assembly. Use only genuine and original authentic XRAY parts for maximum performance. Using any third party parts on this model will void guaranty immediately.

IMPORTANT NOTES - GENERAL

- This product is not suitable for children under 16 years of age without the direct supervision of a responsible and knowledgeable adult.
- Carefully read all manufacturers warnings and cautions for any parts used in the construction and use of your model.
- Assemble this kit only in places away from the reach of very small children.
- First-time builders and users should seek advice from people who have building experience in order to assemble the model correctly and to allow the model to reach its performance potential.
- Exercise care when using tools and sharp instruments.
- Take care when building, as some parts may have sharp edges.
- Keep small parts out of reach of small children. Children must not be allowed to put any parts in their mouth, or pull vinyl bag over their head.
- Read and follow instructions supplied with paints and/or cement, if used (not included in kit).
- Immediately after using your model, do NOT touch equipment on the model such as the motor and speed controller, because they generate high temperatures. You may seriously burn yourself seriously touching them.
- Follow the operating instructions for the radio equipment at all times.
- Do not put fingers or any objects inside rotating and moving parts, as this may cause damage or serious injury as your finger, hair, clothes, etc. may get caught.
- Be sure that your operating frequency is clear before turning on or running your model, and never share the same frequency with somebody else at the same time. Ensure that others are aware of the operating frequency you are using and when you are using it.
- Use a transmitter designed for ground use with RC cars. Make sure that no one else is using the same frequency as yours in your operating area. Using the same frequency at the same time, whether it is driving, flying or sailing, can cause loss of control of the RC model, resulting in a serious accident.
- Always turn on your transmitter before you turn on the receiver in the car. Always turn off the receiver before turning your transmitter off.

IMPORTANT NOTES - NITRO ENGINES

- Always test the brakes and the throttle before starting your engine to avoid losing control of the model.
- Make sure the air filter is clean and oiled.
- Never run your engine without an air filter. Your engine can be seriously damaged if dirt and debris get inside the engine.

Improper operation may cause personal and/or property damage. XRAY and its distributors have no control over damage resulting from shipping, improper construction, or improper usage. XRAY assumes and accepts no responsibility for personal and/or property damages resulting from the use of improper building materials, equipment and operations. By purchasing any item produced by XRAY, the buyer expressly warrants that he/she is in compliance with all applicable federal, state and local laws and regulation regarding the purchase, ownership and use of the item. The buyer expressly agrees to indemnify and hold harmless XRAY for all claims resulting directly or indirectly from the purchase, ownership or use of the product. By the act of assembling or operating this product, the user accepts all resulting liability. If the buyer is not prepared to accept this liability, then he/she should return this kit in new, unassembled, and unused condition to the place of purchase.

- Keep the wheels of the model off the ground when checking the operation of the radio equipment.
- Disconnect the battery pack before storing your model.
- When learning to operate your model, go to an area that has no obstacles that can damage your model if your model suffers a collision.
- Remove any sand, mud, dirt, grass or water before putting your model away.
- If the model behaves strangely, immediately stop the model, check and clear the problem.
- To prevent any serious personal injury and/or damage to property, be responsible when operating all remote controlled models.
- The model car is not intended for use on public places and roads or areas where its operation can conflict with or disrupt pedestrian or vehicular traffic.
- Because the model car is controlled by radio, it is subject to radio interference from many sources that are beyond your control. Since radio interference can cause momentary loss of control, always allow a safety margin in all directions around the model in order to prevent collisions.
- Do not use your model:
 - Near real cars, animals, or people that are unaware that an RC car is being driven.
 - In places where children and people gather
 - In residential districts and parks
 - In limited indoor spaces
 - In wet conditions
 - In the street
 - In areas where loud noises can disturb others, such as hospitals and residential areas.
 - At night or anytime your line of sight to the model may be obstructed or impaired in any way.

To prevent any serious personal injury and/or damage to property, please be responsible when operating all remote controlled models.

- For proper engine break-in, please refer to the manual that came with the engine.
- Do not run near open flames or smoke while running your model or while handling fuel.
- Some parts will be hot after operation. Do not touch the exhaust or the engine until they have cooled. These parts may reach 275°F during operation!

IMPORTANT NOTES - ELECTRICAL

- Insulate any exposed electrical wiring (using heat shrink tubing or electrical tape) to prevent dangerous short circuits. Take maximum care in wiring, connecting and insulating cables. Make sure cables are always connected securely. Check connectors for if they become loose. And if so, reconnect them securely. Never use R/C models with damaged wires. A damaged wire is extremely dangerous, and can cause short-circuits resulting in fire. Please have wires repaired at your local hobby shop.
- Low battery power will result in loss of control. Loss of control can occur due to a weak battery in either the transmitter or the receiver. Weak running battery may also result in an out of control car if your car's receiver power is supplied by the running battery. Stop operation immediately if the car starts to slow down.
- When not using RC model, always disconnect and remove battery.
- Do not disassemble battery or cut battery cables. If the running battery short-circuits, approximately 300W of electricity can be discharged, leading to fire or burns. Never disassemble battery or cut battery cables.
- Use a recommended charger for the receiver and transmitter batteries and follow

IMPORTANT NOTES - NITRO FUEL

- Handle fuel only outdoors. Never handle nitro fuel indoors, or mix nitro fuel in a place where ventilation is bad.
- Only use nitro fuel for R/C models. Do not use gasoline or kerosene in R/C models as it may cause a fire or explosion, and ruin your engine.
- Nitro fuel is highly inflammable, explosive, and poisonous. Never use fuel indoors or in places with open fires and sources of heat.
- Always keep the fuel container cap tightly shut.
- Always read the warning label on the fuel container for safety information.
- Nitro-powered model engines emit poisonous vapors and gasses. These vapors irritate eyes and can be highly dangerous to your health. We recommend wearing rubber or vinyl gloves to avoid direct contact with nitro fuel.
- Nitro fuel for RC model cars is made of the combination of the methyl alcohol,

- the instructions correctly. Over-charging, incorrect charging, or using inferior chargers can cause the batteries to become dangerously hot. Recharge battery when necessary. Continual recharging may damage battery and, in the worst case, could build up heat leading to fire. If battery becomes extremely hot during recharging, please ask your local hobby shop for check and/or repair and/or replacement.
- Regularly check the charger for potential hazards such as damage to the cable, plug, casing or other defects. Ensure that any damage is rectified before using the charger again. Modifying the charger may cause short-circuit or overcharging leading to a serious accident. Therefore do not modify the charger.
- Always unplug charger when recharging is finished.
- Do not recharge battery while battery is still warm. After use, battery retains heat. Wait until it cools down before charging.
- Do not allow any metal part to short circuit the receiver batteries or other electrical/electronic device on the model.
- Immediately stop running if your RC model gets wet as may cause short circuit.
- Please dispose of batteries responsibly. Never put batteries into fire.

R/C & BUILDING TIPS

- Make sure all fasteners are properly tightened. Check them periodically.
- Make sure that chassis screws do not protrude from the chassis.
- For the best performance, it is very important that great care is taken to ensure the free movement of all parts.
- Clean all ball-bearings so they move very easily and freely.
- Tap or pre-thread the plastic parts when threading screws.
- Self-tapping screws cut threads into the parts when being tightened. Do not use excessive force when tightening the self-tapping screws because you may strip out the thread in the plastic. We recommended you stop tightening a screw when you feel some resistance.

WARRANTY

XRAY guarantees this model kit to be free from defects in both material and workmanship within 30 days of purchase. The total monetary value under warranty will in no case exceed the cost of the original kit purchased. This warranty does not cover any components damaged by use or modification or as a result of wear. Part or parts missing from this kit must be reported within 30 days of purchase. No part or parts will be sent under warranty without proof of purchase. Should you find a defective or missing part, contact the local distributor. Service and customer support will be provided through local hobby store where you have purchased the kit, therefore make sure to purchase any XRAY products at your local hobby store. This model racing car is considered to be a high-performance racing vehicle. As such this vehicle will be used in an extreme range of conditions and situations, all which may cause premature wear or failure of any component. XRAY has no control over usage of vehicles once they leave the dealer, therefore XRAY can only offer warranty against all manufacturer's defects in materials, workmanship, and assembly at point of sale and before use. No warranties are expressed or implied that cover damage caused by what is considered normal use, or cover or imply how long any model cars' components or electronic components will last before requiring replacement.

Due to the high performance level of this model car you will need to periodically maintain and replace consumable components. Any and all warranty coverage will not cover replacement of any part or component damaged by neglect, abuse, or improper or unreasonable use. This includes but is not limited to damage from crashing, chemical and/or water damage, excessive moisture, improper or no

QUALITY CERTIFICATE

XRAY MODEL RACING CARS uses only the highest quality materials, the best compounds for molded parts and the most sophisticated manufacturing processes of TQM (Total Quality Management). We guarantee that all parts of a newly-purchased kit are manufactured with the highest regard to quality. However, due to the many factors inherent in model racecar competition, we cannot guarantee any parts once

In line with our policy of continuous product development, the exact specifications of the kit may vary. In the unlikely event of any problems with your new kit, you should contact the model shop where you purchased it, quoting the part number. We do reserve all rights to change any specification without prior notice. All rights reserved.

XRAY

- castor or synthetic oil, nitro methane etc. The flammability and volatility of these elements is very high, so be very careful during handling and storage of nitro fuel.
- Keep nitro fuel away from open flame, sources of heat, direct sunlight, high temperatures, or near batteries.
- Store fuel in a cool, dry, dark, well-ventilated place, away from heating devices, open flames, direct sunlight, or batteries. Keep nitro fuel away from children.
- Do not leave the fuel in the carburetor or fuel tank when the model is not in use. There is danger that the fuel may leak out.
- Wipe up any spilled fuel with a cloth.
- Be aware of spilled or leaking fuel. Fuel leaks can cause fires or explosions.
- Do not dispose of fuel or empty fuel containers in a fire. There is danger of explosion.

- Ask your local hobby shop for any advice.

Please support your local hobby shop. We at XRAY Model Racing Cars support all local hobby dealers. Therefore we ask you, if at all possible, to purchase XRAY products at your hobby dealer and give them your support like we do. If you have difficulty finding XRAY products, please check out www.teamxray.com to get advice, or contact us via email at info@teamxray.com, or contact the XRAY distributor in your country.

maintenance, or user modifications which compromise the integrity of components. Warranty will not cover components that are considered consumable on RC vehicles. XRAY does not pay nor refund shipping on any component sent to XRAY or its distributors for warranty. XRAY reserves the right to make the final determination of the warranty status of any component or part.

Limitations of Liability

XRAY makes no other warranties expressed or implied. XRAY shall not be liable for any loss, injury or damages, whether direct, indirect, special, incidental, or consequential, arising from the use, misuse, or abuse of this product and/or any product or accessory required to operate this product. In no case shall XRAY's liability exceed the monetary value of this product.

Take adequate safety precautions prior to operating this model. You are responsible for this model's assembly and safe operation.

Disregard of the any of the above cautions may lead to accidents, personal injury, or property damage. XRAY MODEL RACING CARS assumes no responsibility for any injury, damage, or misuse of this product during assembly or operation, nor any additions that may arise from the use of this product.

All rights reserved.

you start racing the car. Products which have been worn out, abused, neglected or improperly operated will not be covered under warranty.

We wish you enjoyment of this high-quality and high-performance RC car and wish you best success on the track!

SYMBOLS USED

Part bags used 	Assemble in the specified order 	Assemble left and right sides the same way 	Assemble front and rear the same way 	Pay attention here 	Assemble as many times as specified (here twice) 	Apply instant glue 	Apply oil 	Apply grease 	Apply threadlock
Cut off shaded portion 	Use special tool 	Cut off remaining material 	Time 	Use cleaner 	Tighten screw gently 	Ensure smooth non-binding movement 	Use pliers 	Follow tip here 	Follow Set-Up Book

TOOLS REQUIRED

Phillips 5.0mm (HUDY TOOLS) Allen 1.5 / 2.0 / 2.5mm (HUDY TOOLS) ARM REAMER 3mm/4mm (HUDY TOOLS) Socket 5.0 / 5.5mm (HUDY TOOLS)	17mm Wheel Nut Tool (HUDY #107570)	Flywheel Tool (HUDY #182015)	Special Tool for all turnbuckles, nuts (HUDY #108090)	Cross wrench (HUDY #107581)	
Side Cutters (HUDY #189010)	Hobby Knife	Needle Nose Pliers (HUDY #189020)	Snap Ring Pliers (HUDY #189040)	Scissors (HUDY #188990)	Body Reamer (HUDY #107600) or (HUDY #107601)

TOOLS & EQUIPMENT INCLUDED

Silicone Shock Oil	Silicone Diff Oil	Air Filter Oil	Graphite Grease (HUDY #106210)
--------------------	-------------------	----------------	--------------------------------

EQUIPMENT REQUIRED

Transmitter Receiver Steering and Throttle Servos	.21 Engine	Manifold Exhaust	Starter Box & Battery Pack	Glow Plug Igniter	Battery Charger
Receiver Pack	Threadlock	CA Glue	Transmitter Batteries	Fuel	Lexan™ Paint

TIP FRONT & REAR DIFF GEAR MESH ADJUSTMENT

Before filling in the differentials with oil we suggest that you first check gear mesh as below. If there is too much or too little diff side play, this may create non-optimal gear mesh between the diff gear and the pinion drive gear. This is easily resolved by inserting 1 or 2 of the included thin shims behind a diff outdrive ball-bearing, depending on how much play there is.

THE LOCATION OF THE SHIM(S) DEPENDS ON WHETHER YOU ARE TRYING TO CLOSE OR OPEN THE GAP:

INCLUDED SHIM

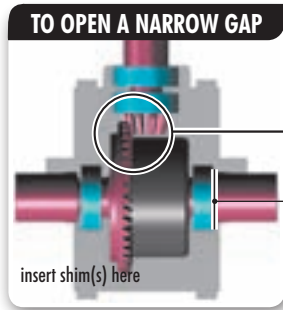
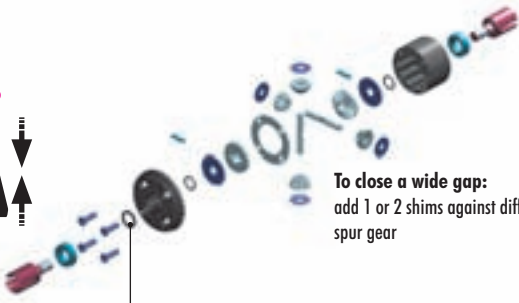
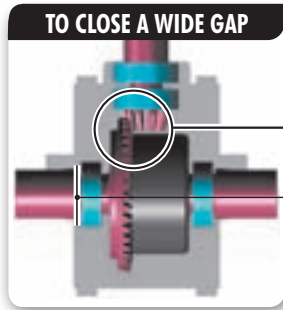

OPTIONAL SHIM

For easier gear mesh adjustments, optional S13 x 0.2 shims are used. These shims can be placed behind the bearing which is quicker.

To close a wide gap:
add 1 or 2 shims against diff spur gear

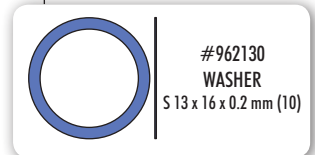

To open a narrow gap:
add 1 or 2 shims on the other side of the diff, away from spur gear

TIP DRIVE SHAFT PINS SERVICING

To enjoy the longest possible lifespan of the drive shafts and diff outdrives, it is extremely important to properly service the drive shaft pins. Inspect the pins after every 3 hours of runtime. If the pins show any wear, replace them with new pins.



TIP GRAPHITE PARTS PROTECTION

Follow this tech tip to protect the graphite parts.

Protect all XB9 Graphite Parts:

- Front shock tower
- Rear shock tower
- Steering plate

Fine sandpaper

Use fine sandpaper to sand smooth the edges of all graphite parts.



Apply CA glue to all edges of the graphite parts.



TIP INSTALLING PIVOT BALLS INTO COMPOSITE BALL-JOINTS



1. FRONT & REAR DIFFERENTIALS

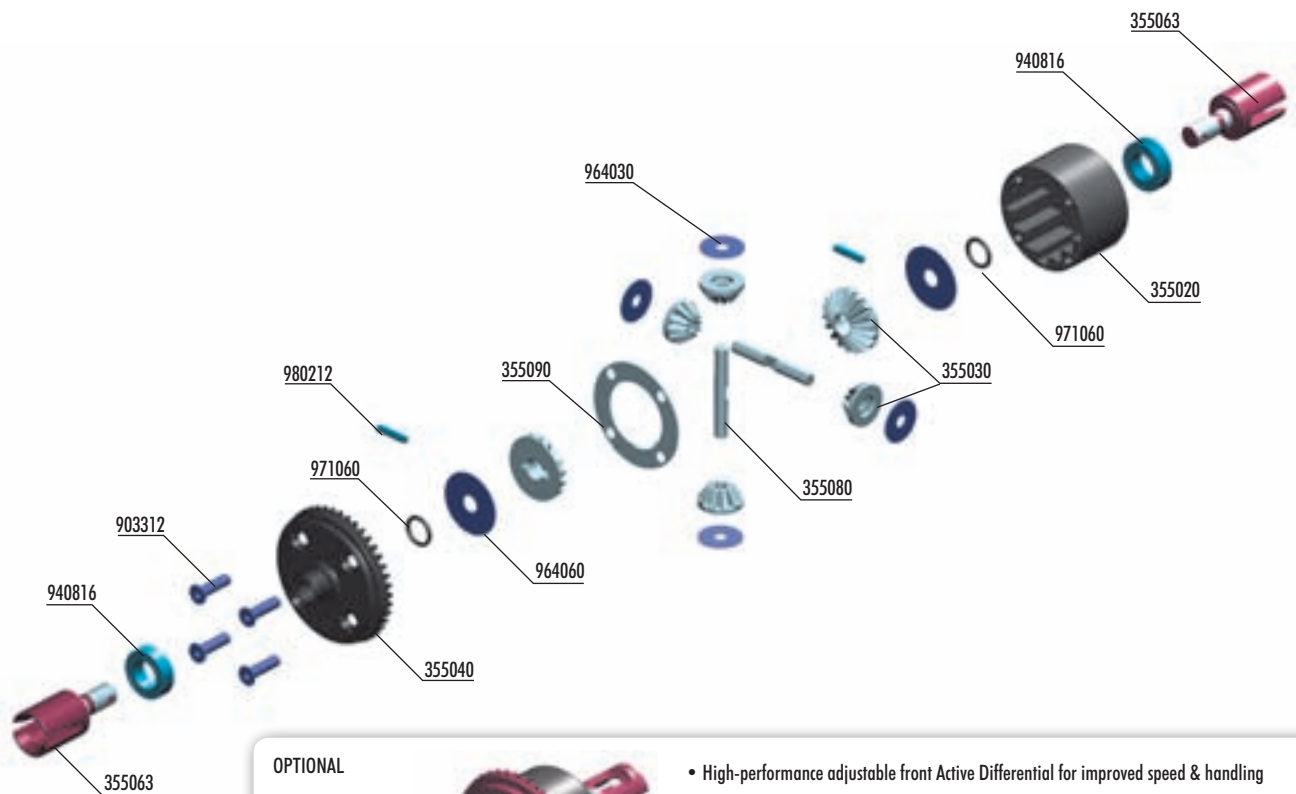

OPTIONAL

ACTIVE FRONT DIFF
#355104

- High-performance adjustable front Active Differential for improved speed & handling
- Fully adjustable on- and off-power performance using different internal segments and gears
- Improves diff action and increases traction
- Easy and consistent steering

BAGS



35 5002	XB9 FRONT/REAR DIFFERENTIAL - SET	90 3312	HEX SCREW SFH M3x12 (10)
35 5020	DIFFERENTIAL CASE	94 0816	HIGH-SPEED BALL-BEARING 8x16x5 (8)
35 5030	STEEL DIFF BEVEL & SATELLITE GEARS (2+4)	96 4030	WASHER S 3.5x12x0.2 (10)
35 5040	FRONT/REAR DIFF LARGE BEVEL GEAR 40T - HUDY STEEL	96 4060	WASHER S 6x18x0.2 (10)
35 5063	F/R DIFF OUTDRIVE ADAPTER - LIGHTW. - HUDY SPRING STEEL™ (2)	97 1060	SILICONE O-RING 6x1.5 (10)
35 5080	DIFF PIN (2)	98 0212	PIN 2x11.6 (10)
35 5090	DIFF GASKET (4)		

90 3312	HEX SCREW SFH M3x12 (10)
94 0816	HIGH-SPEED BALL-BEARING 8x16x5 (8)
96 4030	WASHER S 3.5x12x0.2 (10)
96 4060	WASHER S 6x18x0.2 (10)
97 1060	SILICONE O-RING 6x1.5 (10)
98 0212	PIN 2x11.6 (10)

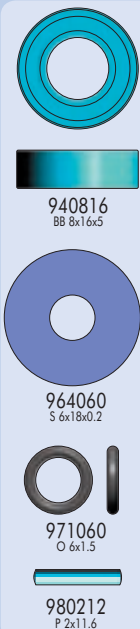

FRONT/REAR DIFF LARGE BEVEL GEAR	
#355040	DIFF LARGE BEVEL GEAR 40T (STANDARD)
#355038	DIFF LARGE BEVEL GEAR 38T (OPTION)

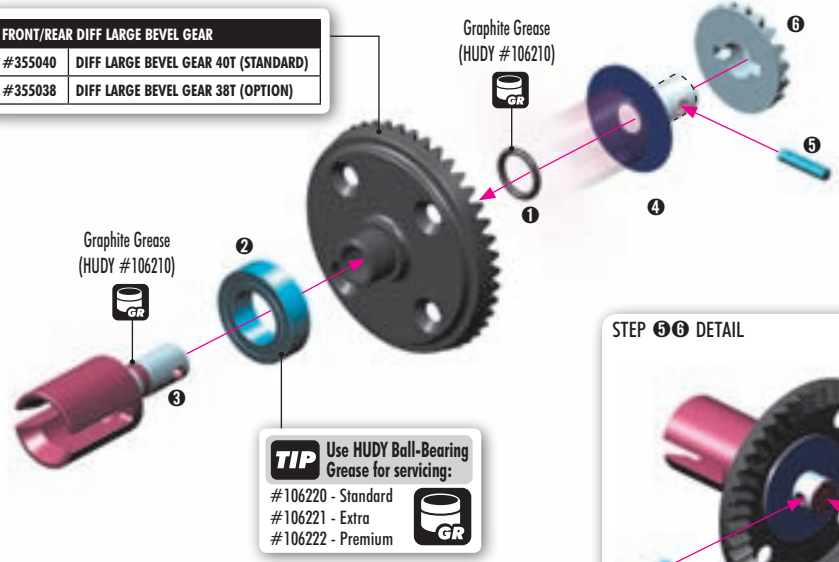

TIP Use HUDY Ball-Bearing Grease for servicing:
#106220 - Standard
#106221 - Extra
#106222 - Premium

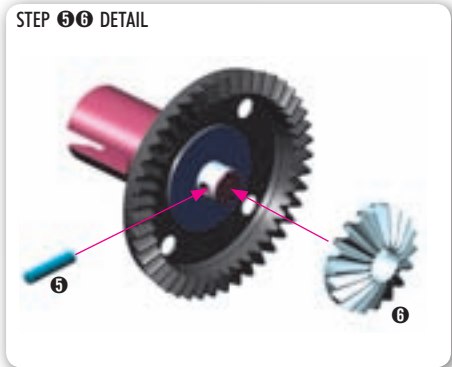

SET-UP BOOK
DIFFERENTIAL GEARS

FRONT & REAR DIFFERENTIALS

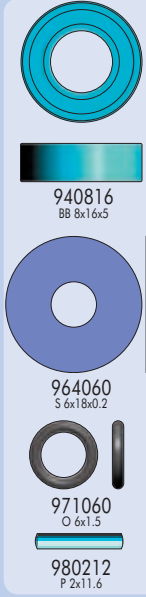

2x F=R

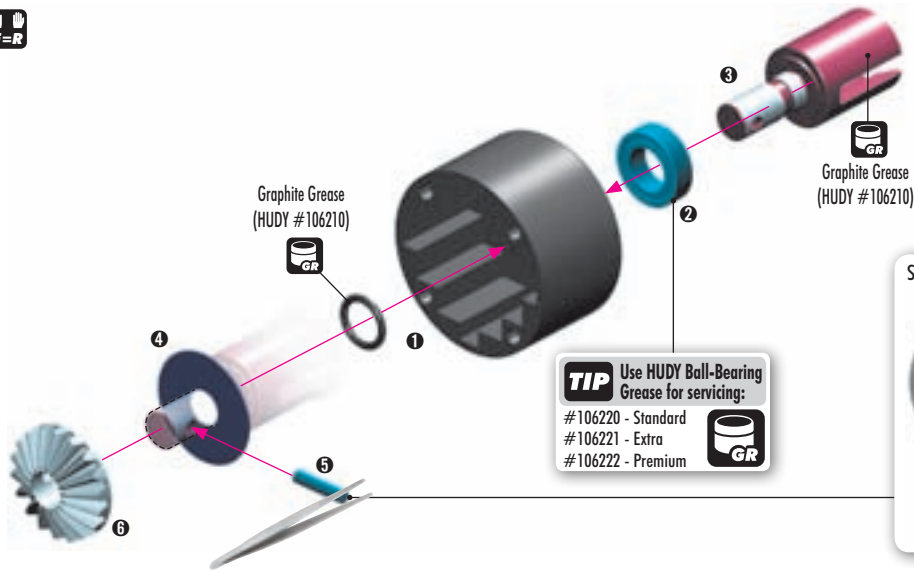

TIP Use HUDY Ball-Bearing Grease for servicing:
 #106220 - Standard
 #106221 - Extra
 #106222 - Premium

STEP 5 DETAIL



VERY IMPORTANT!

Use these silicone oils included in the kit for initial settings:
 Front diff: 5000cSt / Rear diff: 2000cSt

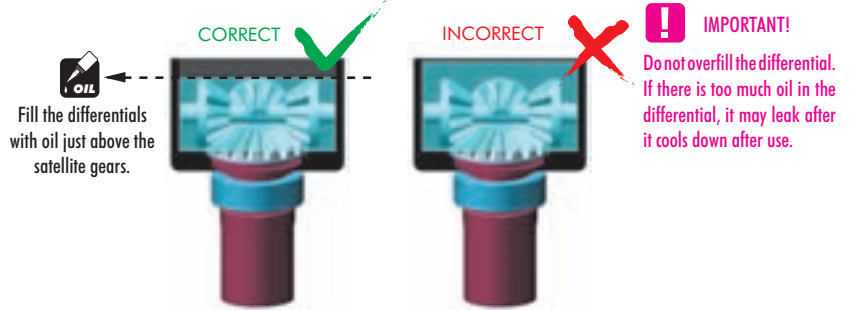

To ensure you have the same amount of oil from rebuild to rebuild, do the following:

#107865 HUDY Ultimate Digital Pocket Scale 300g ± 0.01g



1. Put the diff (without oil) on the scale and check the weight (approximately 40.95g).

2. Slowly pour oil into the diff and watch the weight. Add 2.7g of oil into the diff. The approximate weight of the diff + oil is 43.65g.

SET-UP BOOK
 DIFFERENTIAL OIL

Front diff:

Silicone oil 5000cSt
 Fill just above the satellite gears.

Rear diff:

Silicone oil 2000cSt
 Fill just above the satellite gears.

Tighten the screws equally



Finish tightening in this order

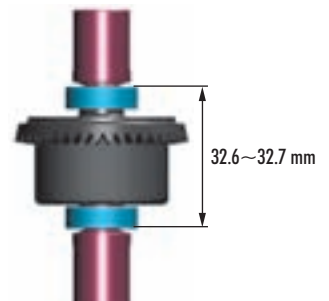
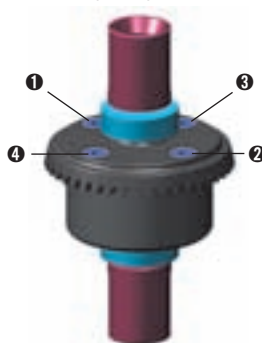

After assembly the differentials should have a length of 32.6~32.7 mm measured from the ends of the installed ball-bearings. If differentials are longer, retighten the 4 screws holding the crown gears.

CENTER DIFFERENTIAL

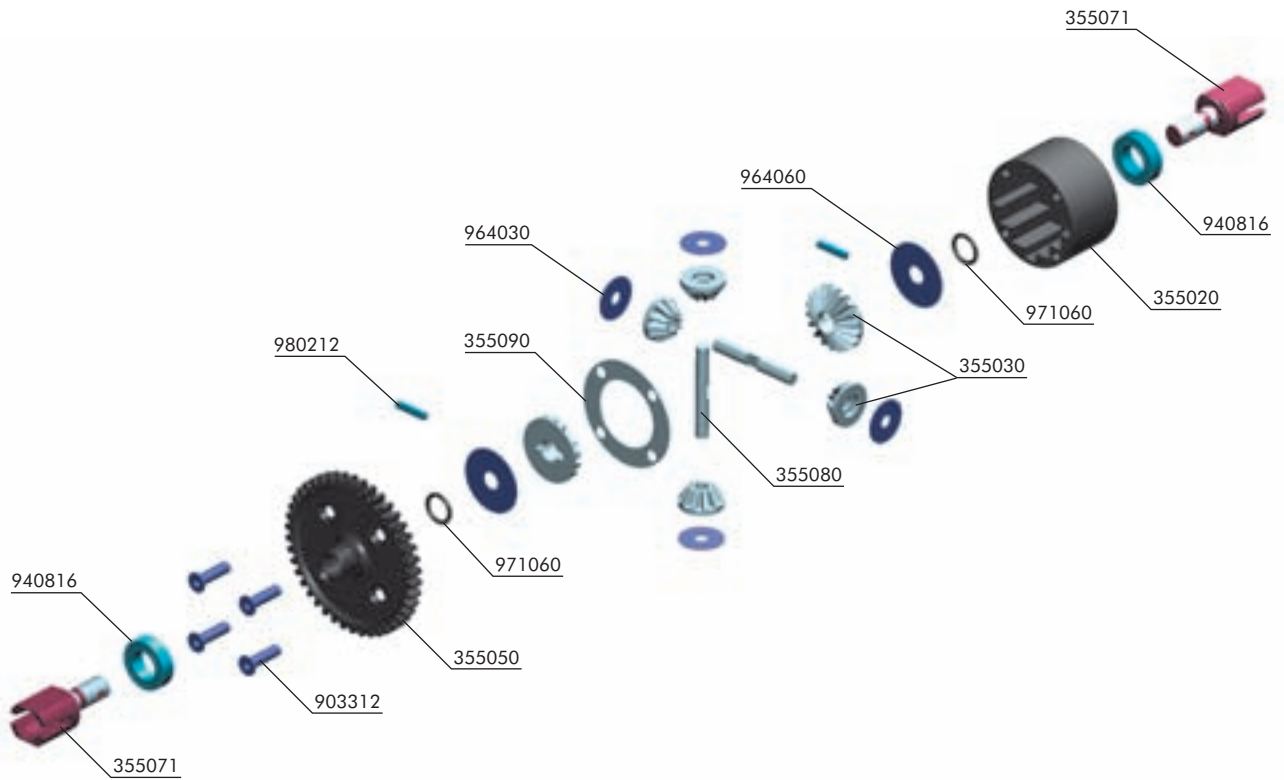

BAG

01.3

- | | | | |
|---------|---|---------|---|
| 35 5012 | XB9 CENTRAL DIFFERENTIAL - SET | 94 0816 | HIGH-SPEED BALL-BEARING 8x16x5 BLUE COVERED (2) |
| 35 5020 | DIFFERENTIAL CASE | 96 4030 | WASHER S 3.5x12x0.2 (10) |
| 35 5030 | STEEL DIFF BEVEL & SATELLITE GEARS (2+4) | 96 4060 | WASHER S 6x18x0.2 (10) |
| 35 5050 | CENTER DIFF SPUR GEAR 46T | 97 1060 | SILICONE O-RING 6x1.5 (10) |
| 35 5071 | CENTER DIFF OUTDRIVE ADAPTER - LIGHTWEIGHT - HUDY STEEL (2) | 98 0212 | PIN 2x11.6 (10) |
| 35 5080 | DIFF PIN (2) | | |
| 35 5090 | DIFF GASKET (4) | | |
| 90 3312 | HEX SCREW SFH M3x12 (10) | | |

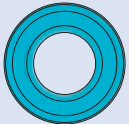

940816
BB 8x16x5



964060
S 6x18x0.2



971060
O 6x1.5



980212
P 2x11.6

SET-UP BOOK

DIFFERENTIAL GEARS

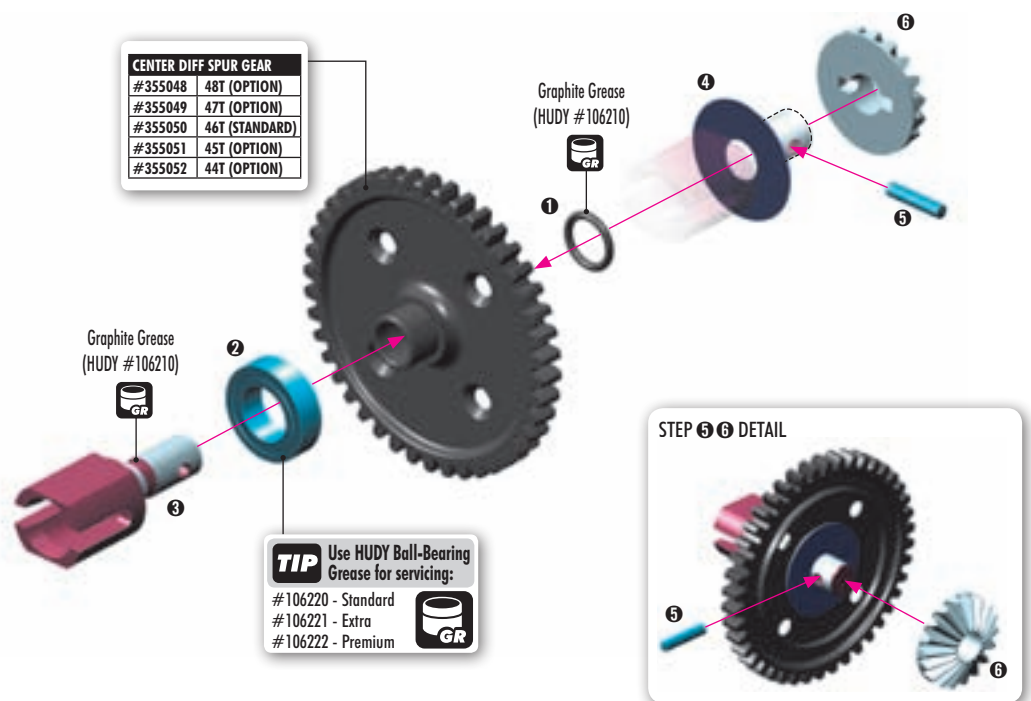

CENTER DIFFERENTIAL



940816
BB 8x16x5



964060
S 6x18x0.2



971060
O 6x1.5

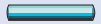

980212
P 2x11.6

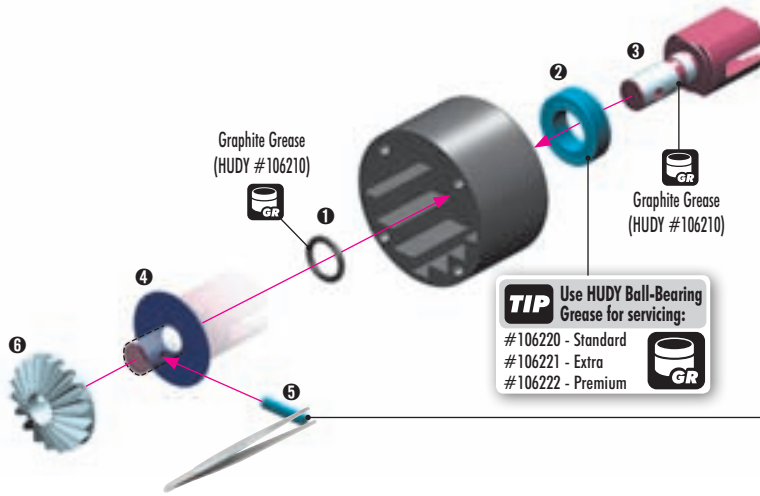

Graphite Grease
(HUDY #106210)

Graphite Grease
(HUDY #106210)

TIP Use HUDY Ball-Bearing Grease for servicing:
#106220 - Standard
#106221 - Extra
#106222 - Premium

STEP 5 DETAIL



903312
SFH M3x12



964030
S 3.5x12x0.2

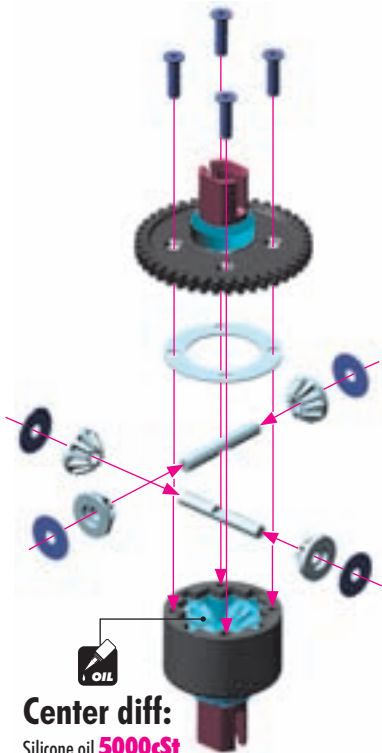

Center diff:

Silicone oil **5000cSt**

Fill to just above the satellite gears.

VERY IMPORTANT!

Use the following silicone oil included in the kit for initial setting:

Center diff: **5000cSt**

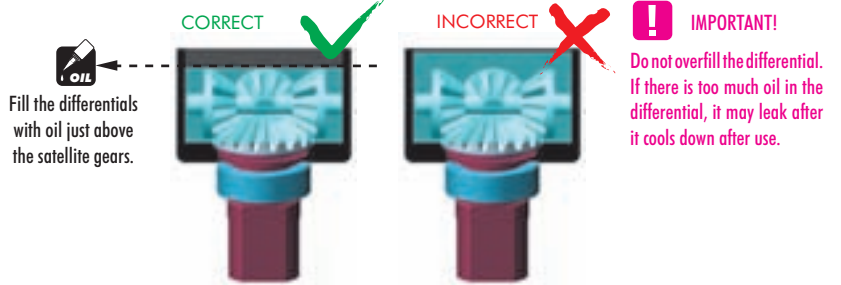

Fill the differentials with oil just above the satellite gears.

To ensure you have the same amount of oil from rebuild to rebuild, do the following:

#107865 HUDY Ultimate Digital Pocket Scale 300g ± 0.01g



1. Put the diff (without oil) on the scale and check the weight (approximately 40.95g).

2. Slowly pour oil into the diff and watch the weight. Add 2.7g of oil into the diff. The approximate weight of the diff + oil is 43.65g.

Tighten the screws equally



Finish tightening in this order

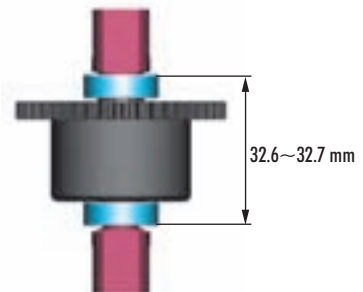
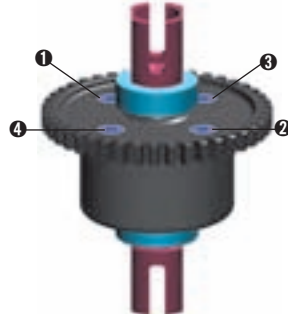

After assembly the differential should have a length of 32.6~32.7 mm measured from the ends of the installed ball-bearings. If differential is longer, retighten the 4 screws holding the spur gear.

SET-UP BOOK
DIFFERENTIAL OIL

2. FRONT TRANSMISSION

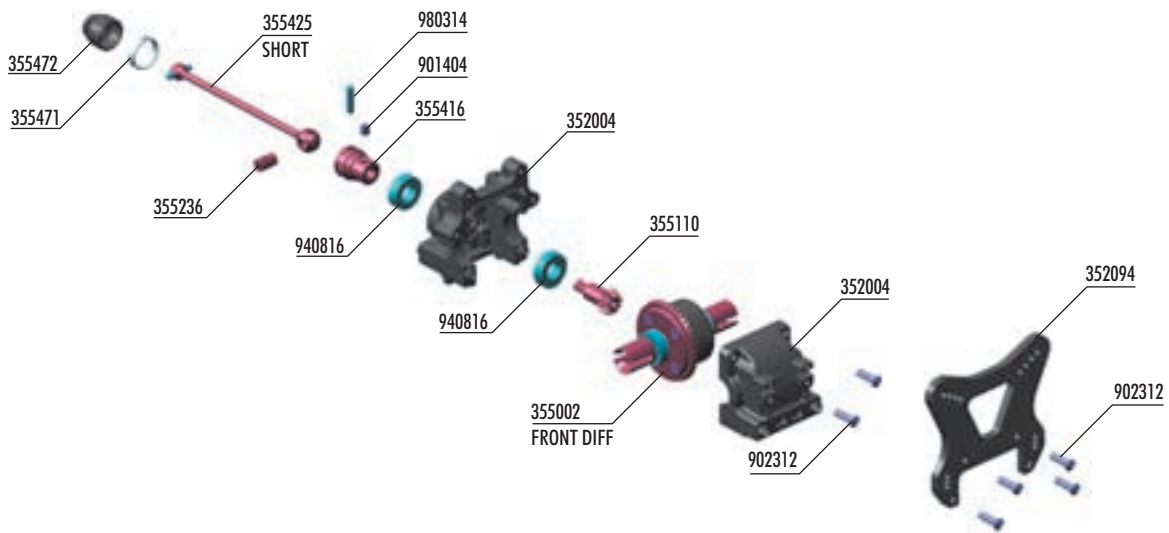

BAG

02

35 2004 DIFF BULKHEAD BLOCK SET FRONT/REAR
 35 2094 XB9 GRAPHITE FRONT SHOCK TOWER - CNC MACHINED 4MM
 35 5110 BEVEL DRIVE GEAR 12T
 35 5236 XB9 CVD DRIVE SHAFT COUPLING - HUDY SPRING STEEL™
 35 5416 XB9 CENTRAL CVD SHAFT UNIVERSAL JOINT - HUDY SPRING STEEL™
 35 5425 XB9 FRONT CENTRAL CVD DRIVE SHAFT - HUDY SPRING STEEL™
 35 5471 XB9 DRIVE SHAFT LOCKING RING (2)

35 5472 XB9 DRIVE SHAFT BOOT (2)
 90 1404 HEX SCREW SB M4x4 (10)
 90 2312 HEX SCREW SH M3x12 (10)
 94 0816 HIGH-SPEED BALL-BEARING 8x16x5 RUBBER SEALED (2)
 98 0314 PIN 3x14 (10)



901404
SB 4x4



902312
SH 3x12

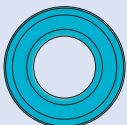

940816
BB 8x16x5



980314
P 3x14

step 1

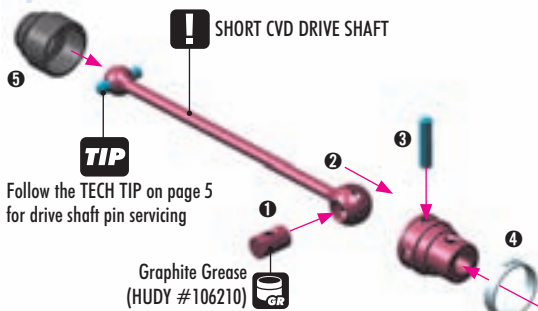

The ring can be assembled with hands but for easy disassembling, we recommend to use snap ring pliers (HUDY #189040)

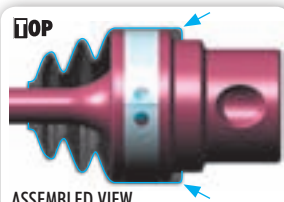

step 2

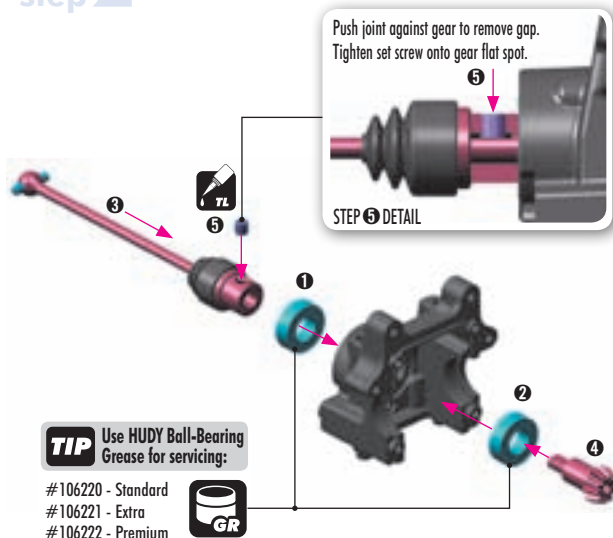

step 3

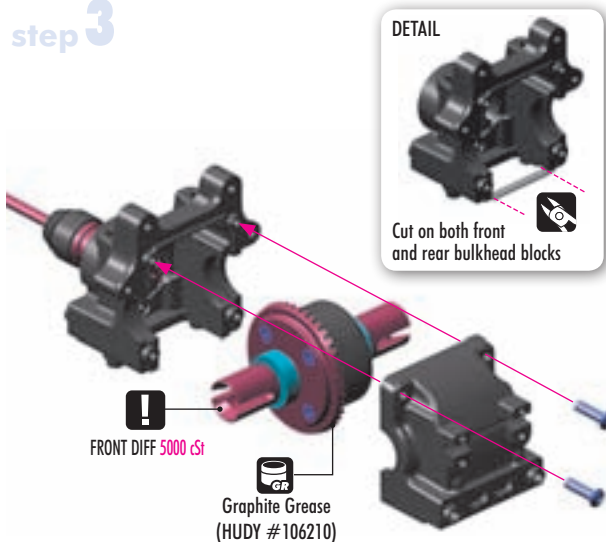

step 4

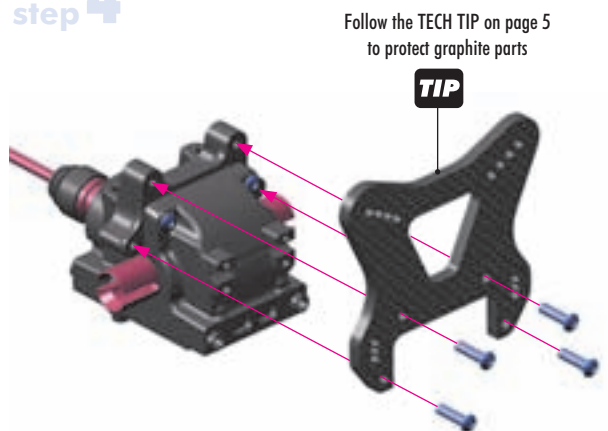

REAR TRANSMISSION

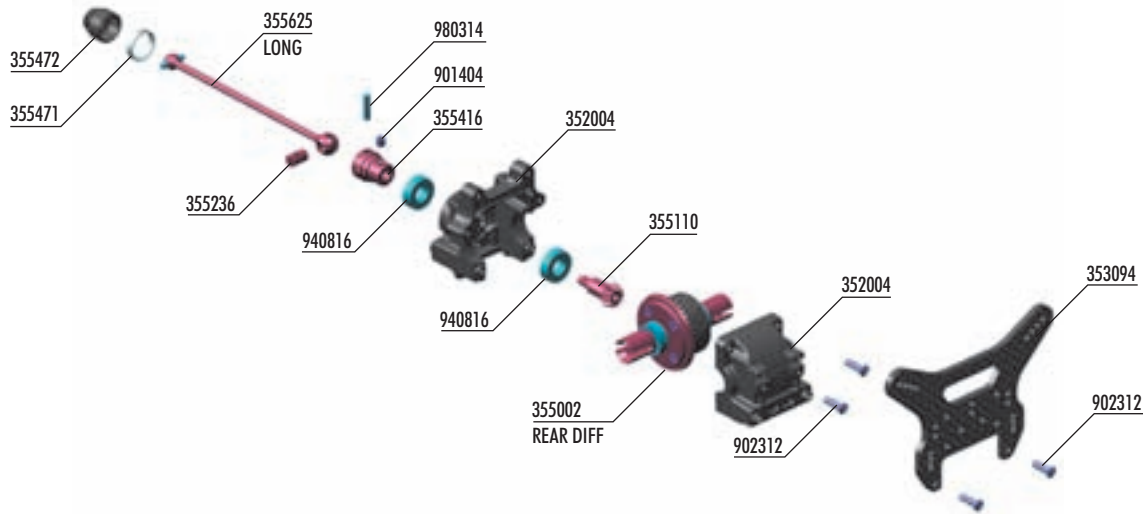

BAG

02

35 2004 DIFF BULKHEAD BLOCK SET FRONT/REAR
 35 3094 XB9 GRAPHITE REAR SHOCK TOWER - CNC MACHINED 3.5MM
 35 5110 BEVEL DRIVE GEAR 12T
 35 5236 XB9 CVD DRIVE SHAFT COUPLING - HUDY SPRING STEEL™
 35 5416 XB9 CENTRAL CVD SHAFT UNIVERSAL JOINT - HUDY SPRING STEEL™
 35 5625 XB9 REAR CENTRAL CVD DRIVE SHAFT - HUDY SPRING STEEL™
 35 5471 XB9 DRIVE SHAFT LOCKING RING (2)

35 5472 XB9 DRIVE SHAFT BOOT (2)
 90 1404 HEX SCREW SB M4x4 (10)
 90 2312 HEX SCREW SH M3x12 (10)
 94 0816 HIGH-SPEED BALL-BEARING 8x16x5 RUBBER SEALED (2)
 98 0314 PIN 3x14 (10)



901404
SB 4x4



902312
SH 3x12



940816
BB 8x16x5



980314
P 3x14

step 1

LONG CVD DRIVE SHAFT

TIP Follow the TECH TIP on page 5 for drive shaft pin servicing

Graphite Grease (HUDY #106210)

The ring can be assembled with hands but for easy disassembling, we recommend to use snap ring pliers (HUDY #189040)

TIP Use HUDY Ball-Bearing Grease for servicing:
 #106220 - Standard
 #106221 - Extra
 #106222 - Premium

STEP 1 DETAIL

ASSEMBLED VIEW

step 2

Push joint against gear to remove gap. Tighten set screw onto gear flat spot.

STEP 2 DETAIL

TIP Use HUDY Ball-Bearing Grease for servicing:
 #106220 - Standard
 #106221 - Extra
 #106222 - Premium

step 3

DETAIL

Cut on both front and rear bulkhead blocks

REAR DIFF 2000 cSt

Graphite Grease (HUDY #106210)

step 4

Follow the TECH TIP on page 5 to protect graphite parts

TIP

3. REAR SUSPENSION

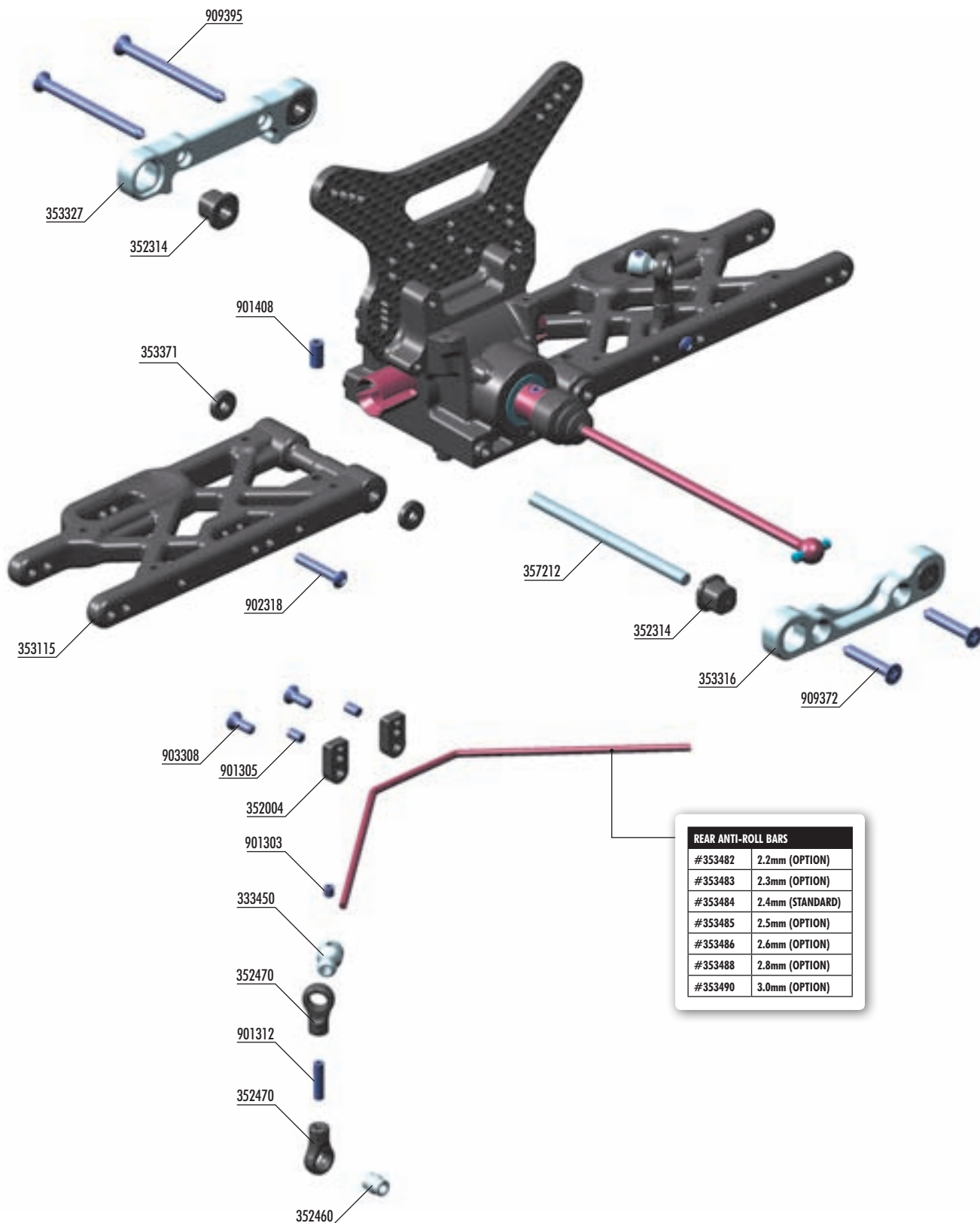

REAR ANTI-ROLL BARS	
#353482	2.2mm (OPTION)
#353483	2.3mm (OPTION)
#353484	2.4mm (STANDARD)
#353485	2.5mm (OPTION)
#353486	2.6mm (OPTION)
#353488	2.8mm (OPTION)
#353490	3.0mm (OPTION)

BAG

03

- 33 3450 ANTI-ROLL BAR BALL JOINT 5.8 MM (2)
- 35 2004 DIFF BULKHEAD BLOCK SET FRONT/REAR
- 35 2314 COMPOSITE ECCENTRIC BUSHINGS (2)
- 35 2460 PIVOT BALL 5.8 (10)
- 35 2470 BALL JOINT 5.8 (8)
- 35 3115 XB9 COMPOSITE REAR LOWER SUSPENSION ARM
- 35 3304 ALU REAR LOWER SUSP. HOLDERS SET- SQUARE ADJ. ROLL-CENTER
- 35 3316 ALU REAR LOWER SUSP. HOLDER - FRONT - SQUARE ADJ. ROLL-CENTER
- 35 3327 ALU REAR LOWER SUSP. HOLDER - REAR - SQUARE ADJ. ROLL-CENTER
- 35 3371 SET OF COMPOSITE LOWER ARM SHIMS

- 35 3484 REAR ANTI-ROLL BAR 2.4MM
- 35 7212 LOWER INNER PIVOT PIN F+R (2)
- 90 1303 HEX SCREW SB M3x3 (10)
- 90 1305 HEX SCREW SB M3x5 (10)
- 90 1312 HEX SCREW SB M3x12 (10)
- 90 1408 HEX SCREW SB M4x8 (10)
- 90 2318 HEX SCREW SH M3x18 (10)
- 90 3308 HEX SCREW SFH M3x8 (10)
- 90 9372 SCREW PHILLIPS SS 3.5x22 (10)
- 90 9395 SCREW PHILLIPS SS 3.5x45 (10)



909395
SS 3.5x45

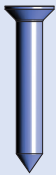

909372
SS 3.5x22



901408
SB M4x8

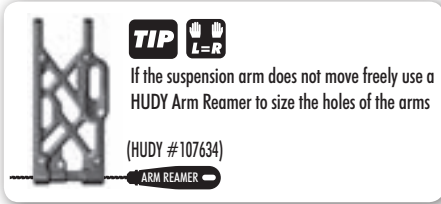
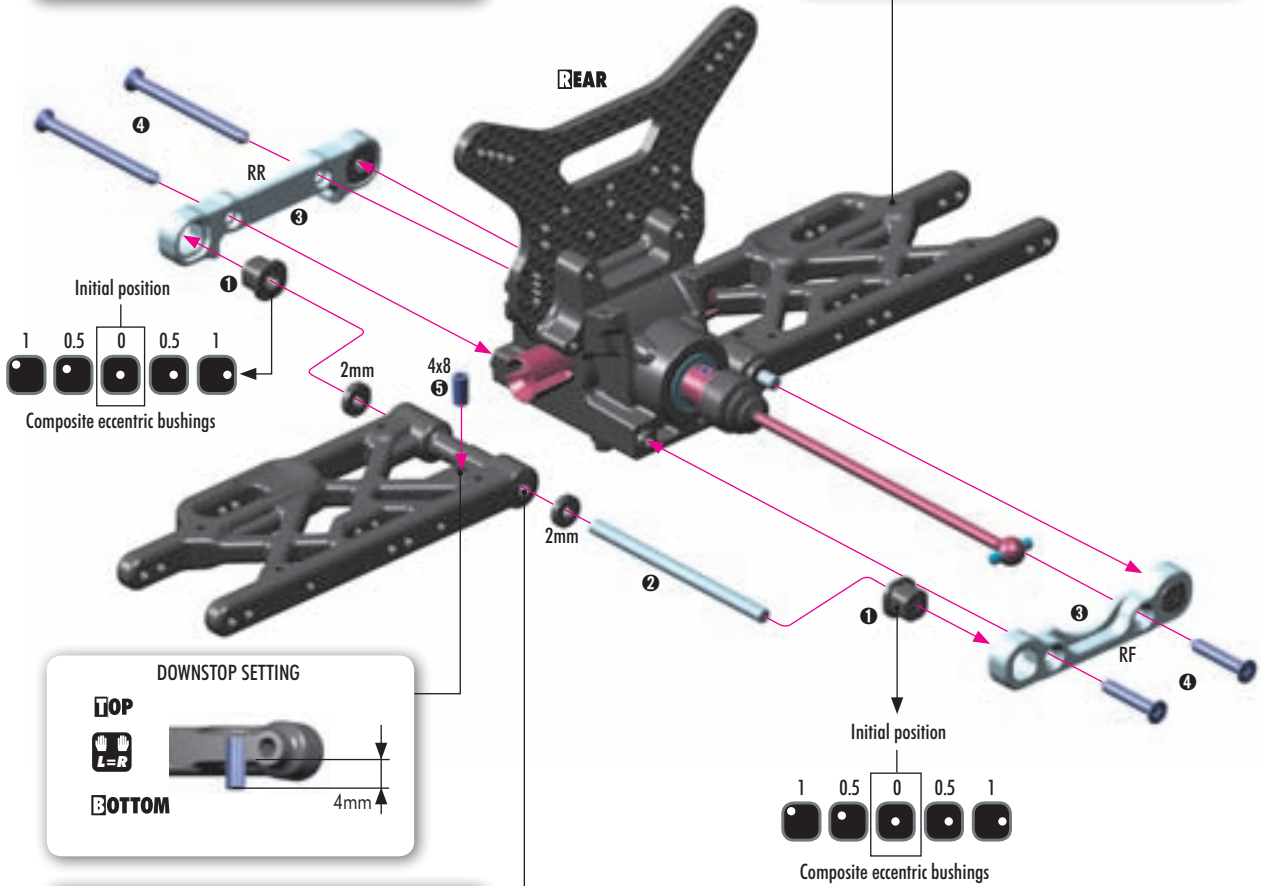
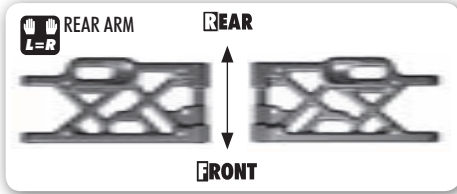

All possible mounting alternatives of eccentric bushings

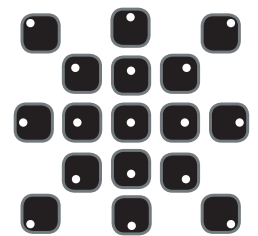

ECCENTRIC BUSHINGS HAVE TWO DIFFERENT OFFSETS FROM THE CENTER.

- Middle position = 0.5 mm or 0.5° from center
- Outer position = 1 mm or 1° from center

The new XRAY rear alu lower suspension holders provide even greater range of adjustment for the rear suspension. Using different combinations of eccentric bushings, fine adjustment of rear anti-squat, rear toe-in, rear roll center, and rear track-width can be obtained. For more information about the influence of rear anti-squat, rear toe-in, rear roll center and rear track-width on car handling, please refer to HUDY Off-Road Set-up Book (#209099).

ANTI-SQUAT		
RR	RF	(°)
0	0	=3°
0.5	0.5	=4°
1	1	=2°
0.5	0.5	=4°
0	0	=3°
0.5	0.5	=5°
1	1	=2°
0.5	0.5	=3°
0	0	=1°

ROLL-CENTER		
RR	RF	(mm)
0	0	=0mm
0.5	0.5	=1mm
1	1	=-1mm

TRACK WIDTH		
RR	RF	(mm)
0	0	=308
0.5	0.5	=306
1	1	=310

TOE-IN		
RR	RF	(°)
0	0	=3°
0.5	0.5	=4°
1	1	=2°
0.5	0.5	=2°
0	0	=3°
0.5	0.5	=1°
1	1	=4°
0.5	0.5	=5°
0	0	=3°

The tables describe the amounts of rear anti-squat, rear toe-in, rear track-width change depending on the combinations of eccentric bushings used with 0 and 1mm, 1° off set. The 0.5mm, 0.5° represent the half change.

- Example: 0(RR) - 0 (RF) = 3°
- 0(RR) - 0.5 (RF) = 3.5°
- 0(RR) - 1 (RF) = 4°

REAR SUSPENSION



901312
SB M3x12

2x L=R

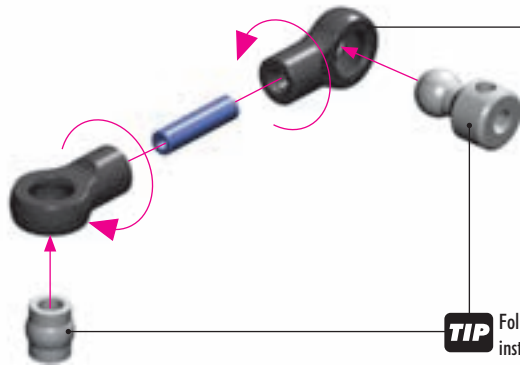

TIP Follow the TECH TIP on page 5 to install the pivot balls



901303
SB M3x3



901305
SB M3x5



902318
SH M3x18



903308
SFH M3x8

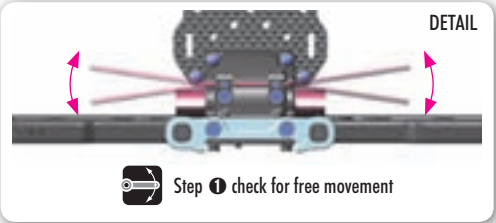
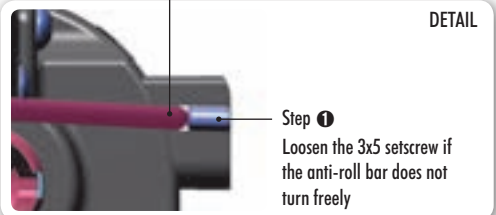
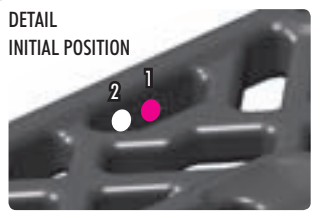
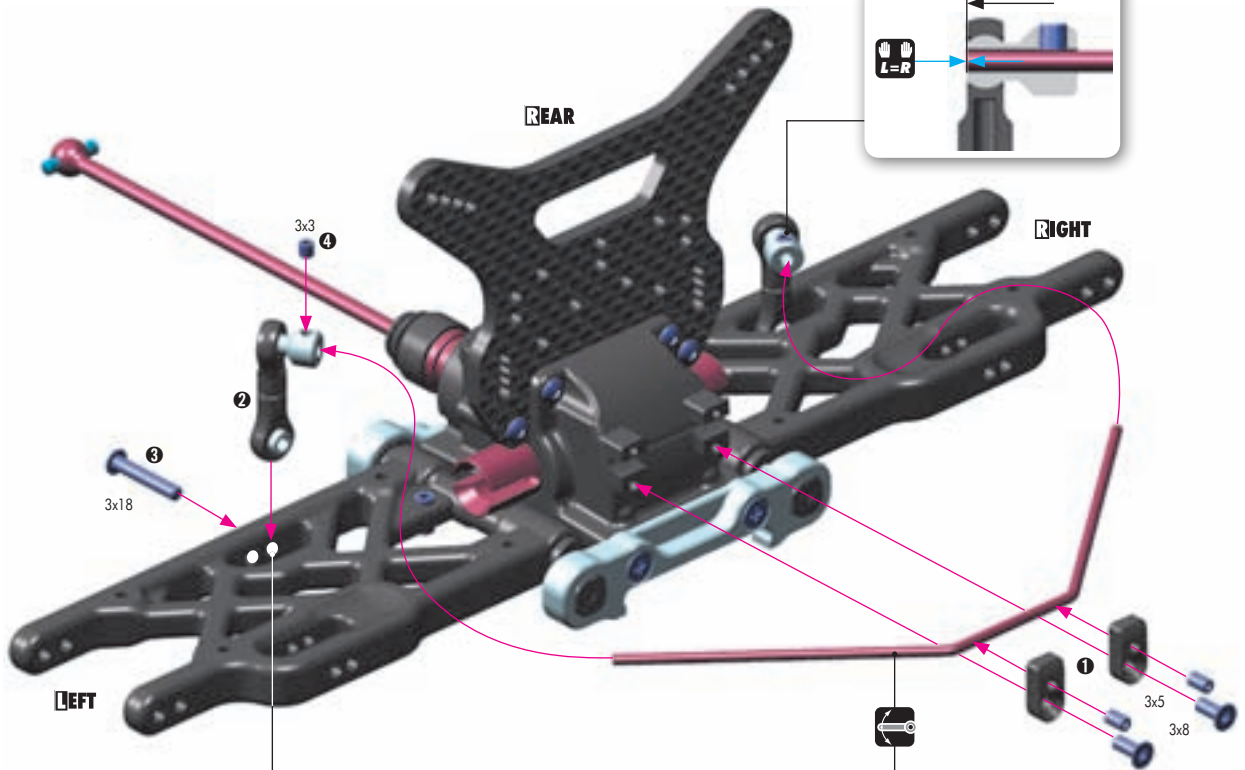

SET-UP BOOK
ANTI-ROLL BAR

4. REAR SUSPENSION

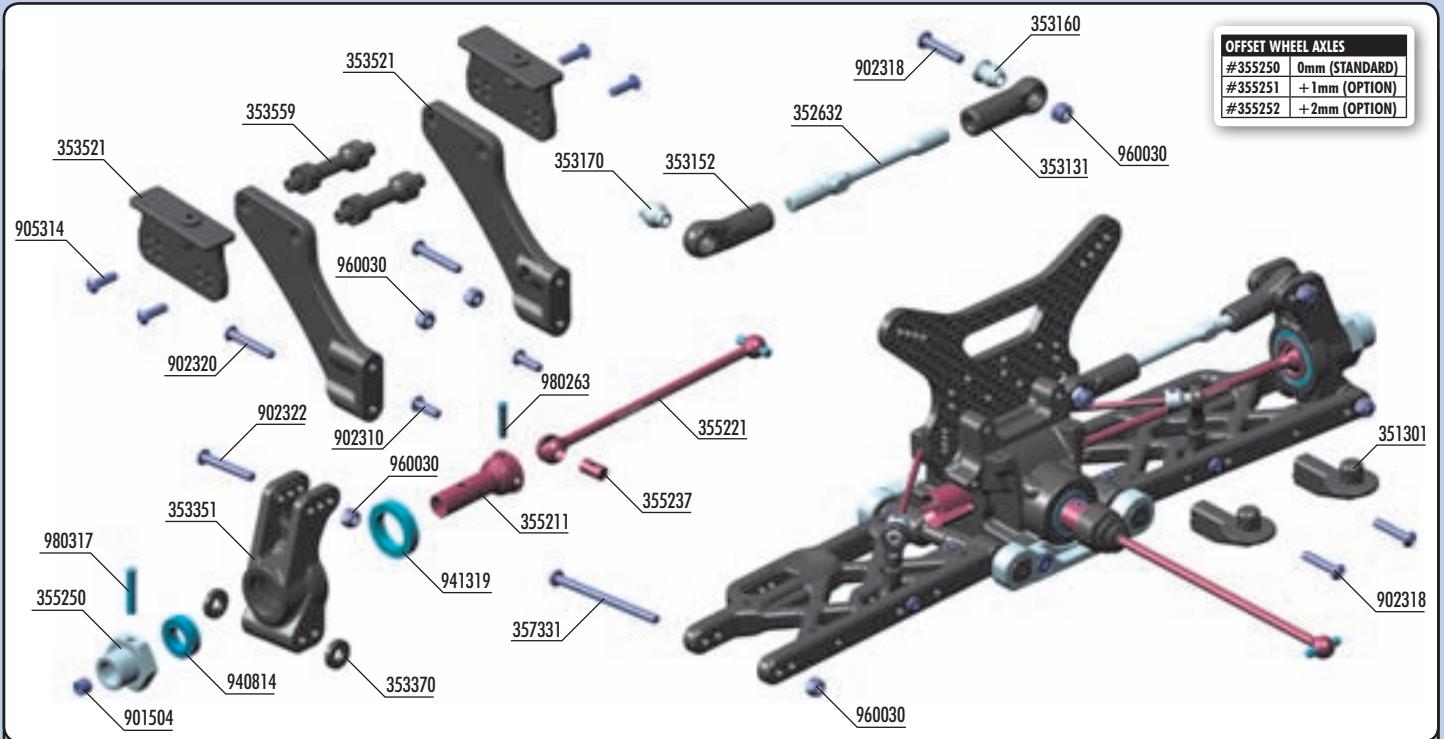

OFFSET WHEEL AXLES	
#35250	0mm (STANDARD)
#35251	+1mm (OPTION)
#35252	+2mm (OPTION)

BAG

04

- | | | | | | |
|---------|---|---------|--|---------|-----------------|
| 35 1301 | BODY POSTS | 35 5237 | CVD DRIVE SHAFT COUPLING - HUDY SPRING STEEL™ | 98 0263 | PIN 2.5x13 (10) |
| 35 2632 | ALU ADJ. TURNBUCKLE 64MM M5 L/R - SWISS 7075 T6 (2) | 35 5250 | ALU WHEEL AXLE - HARD COATED (2) | 98 0317 | PIN 3x17 (10) |
| 35 3131 | REAR UPPER INNER CAMBER LINK BALL JOINT (2) | 35 7331 | XB808 REAR LOWER OUTER PIVOT PIN SCREW 3MM (2) | | |
| 35 3152 | REAR UPPER OUTER CAMBER LINK BALL JOINT (2) | 90 1504 | HEX SCREW SB M5x4 (10) | | |
| 35 3160 | MOUNTING BALL 6.8 (4) | 90 2310 | HEX SCREW SH M3x10 (10) | | |
| 35 3170 | PIVOT BALL 6.8 (4) | 90 2318 | HEX SCREW SH M3x18 (10) | | |
| 35 3351 | XB808 COMPOSITE REAR HUB CARRIER - V2 | 90 2320 | HEX SCREW SH M3x20 (10) | | |
| 35 3370 | SET OF COMPOSITE REAR HUB CARRIER SHIMS | 90 2322 | HEX SCREW SH M3x22 (10) | | |
| 35 3521 | XB9 REAR WING POSTS | 90 5314 | SCREW PHILLIPS 3.0x14 (10) | | |
| 35 3559 | COMPOSITE REAR WING MOUNT BRACE (2) | 94 0814 | HIGH-SPEED BALL-BEARING 8x14x4 BLUE COVERED (2) | | |
| 35 5211 | CVD DRIVE AXLE - HUDY SPRING STEEL™ | 94 1319 | HIGH-SPEED BALL-BEARING 13x19x4 BLUE COVERED (2) | | |
| 35 5221 | CVD UNIVERSAL DRIVE SHAFT - HUDY SPRING STEEL™ | 96 0030 | NUT M3 (10) | | |

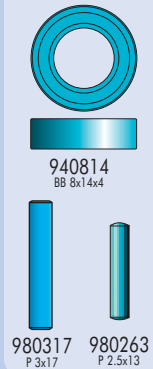
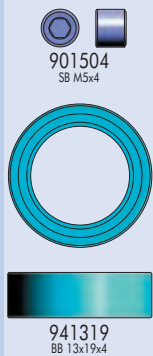

SET-UP BOOK
TRACK WIDTH
WHEELBASE

TIP To tighten the setscrew you can also use the HUDY 17mm Wheel Nut Tool #107570



2x L=R

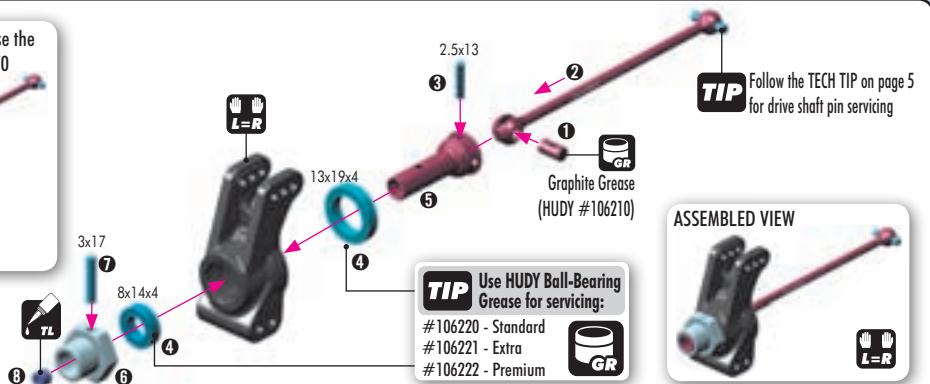

TIP Follow the TECH TIP on page 5 for drive shaft pin servicing

ASSEMBLED VIEW



TIP Use HUDY Ball-Bearing Grease for servicing:
#106220 - Standard
#106221 - Extra
#106222 - Premium

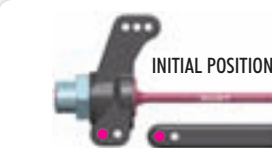

IMPORTANT!

When using outside position on the hub, use only outside position on the arm.

When using inside position on the hub, use only inside position on the arm.

The outside hole offers great stability and is recommended for bumpy open tracks. Inside hole offers great amount of steering and is recommended for flat, technical tracks.

TIP Ensure that the rear upright moves freely. If it does not move freely, use sandpaper to thin both wheelbase adjustment shims.

Shims for wheelbase adjustment

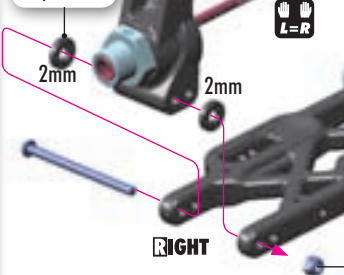

FRONT

LEFT

TIP L=R (HUDY #107633)

If the rear upright does not move freely, use a HUDY Arm Reamer to resize the hole.



Do not overtighten the self-locking nut. Overtightening may result in suspension binding.

Check for free movement

REAR SUSPENSION

SET-UP BOOK

CAMBER

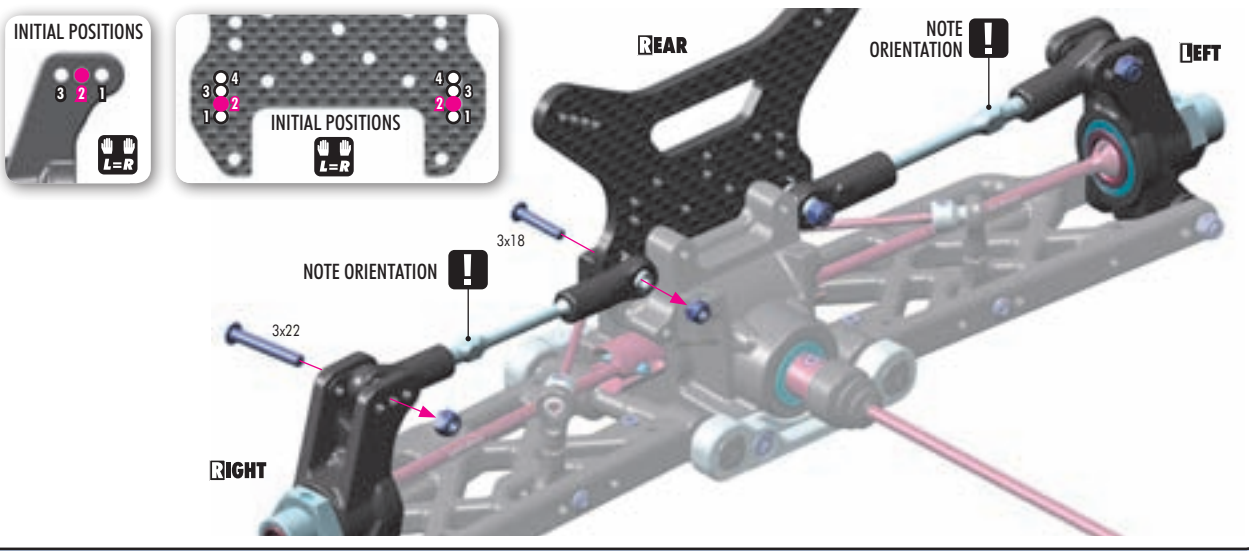
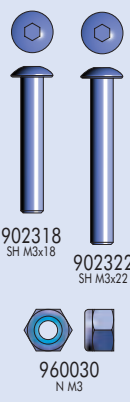
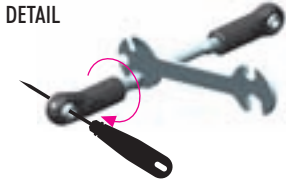
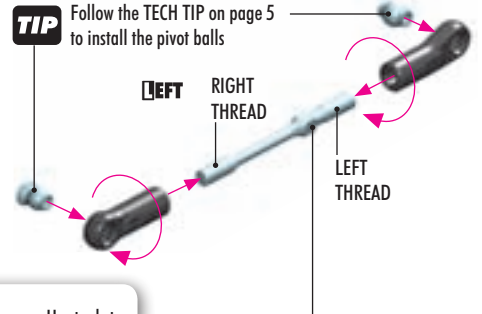
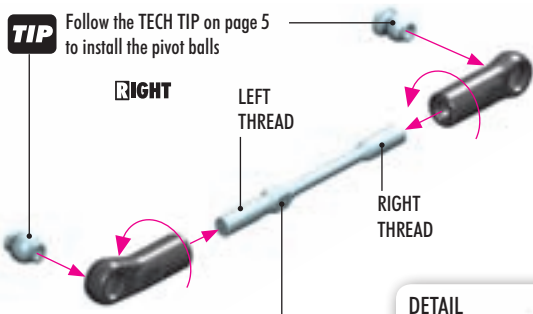

SET-UP BOOK

ROLL CENTER

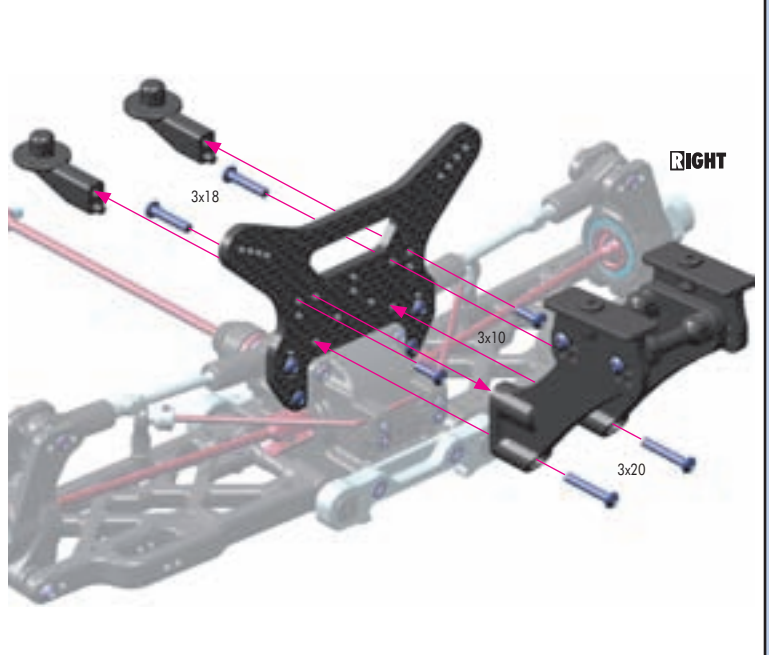
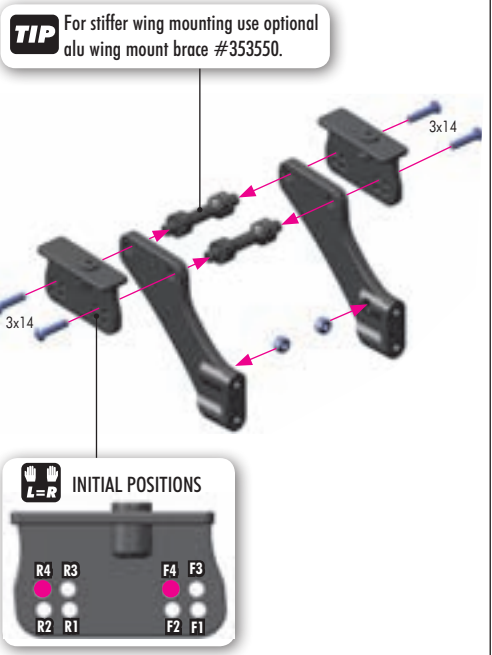

SET-UP BOOK

REAR WING

5. FRONT SUSPENSION

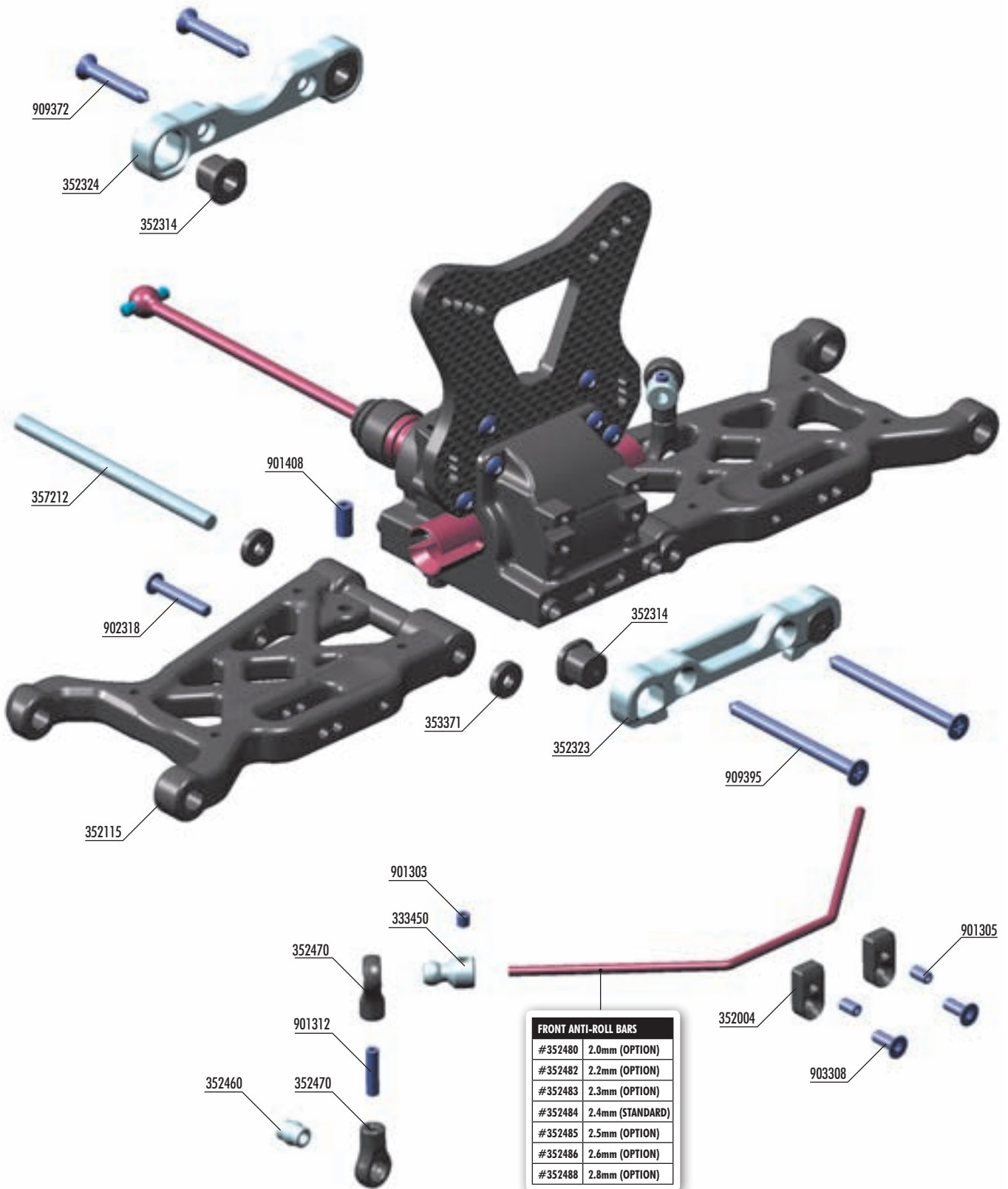

FRONT ANTI-ROLL BARS	
#352480	2.0mm (OPTION)
#352482	2.2mm (OPTION)
#352483	2.3mm (OPTION)
#352484	2.4mm (STANDARD)
#352485	2.5mm (OPTION)
#352486	2.6mm (OPTION)
#352488	2.8mm (OPTION)

BAG

05

- | | | | |
|---------|--|---------|----------------------------------|
| 33 3450 | ANTI-ROLL BAR BALL JOINT 5.8 MM (2) | 35 3371 | SET OF COMPOSITE LOWER ARM SHIMS |
| 35 2004 | DIFF BULKHEAD BLOCK SET FRONT/REAR | 35 7212 | LOWER INNER PIVOT PIN F+R (2) |
| 35 2115 | XB9 COMPOSITE FRONT LOWER SUSPENSION ARM | 90 1303 | HEX SCREW SB M3x3 (10) |
| 35 2304 | ALU FRONT LOWER SUSP. HOLDERS SET - SQUARE ADJ. ROLL-CENTER | 90 1305 | HEX SCREW SB M3x5 (10) |
| 35 2323 | ALU FRONT LOWER SUSP. HOLDER - FRONT - SQUARE ADJ. ROLL-CENTER | 90 1312 | HEX SCREW SB M3x12 (10) |
| 35 2324 | ALU FRONT LOWER SUSP. HOLDER - REAR - SQUARE ADJ. ROLL-CENTER | 90 1408 | HEX SCREW SB M4x8 (10) |
| 35 2314 | COMPOSITE SQUARE ADJ. ROLL-CENTER BUSHINGS (2) | 90 2318 | HEX SCREW SH M3x18 (10) |
| 35 2460 | PIVOT BALL 5.8 (10) | 90 3308 | HEX SCREW SFH M3x8 (10)) |
| 35 2470 | BALL JOINT 5.8 (8) | 90 9372 | SCREW PHILLIPS SS 3.5x22 (10) |
| 35 2484 | FRONT ANTI-ROLL BAR 2.4MM | 90 9395 | SCREW PHILLIPS SS 3.5x45 (10) |

FRONT SUSPENSION



909395
SS 3.5x45



909372
SS 3.5x22



901408
SB M4x8

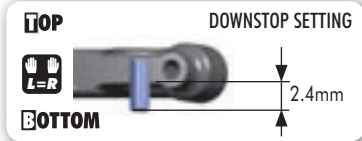
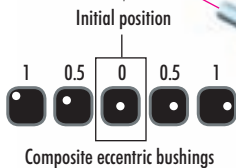
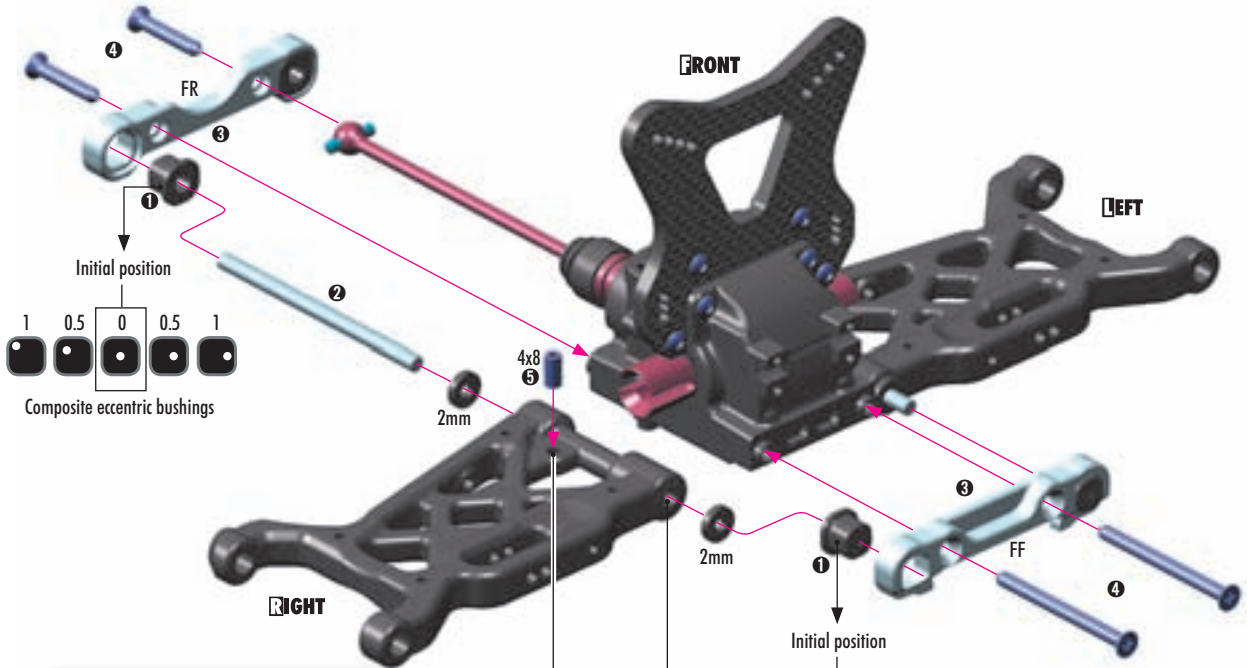
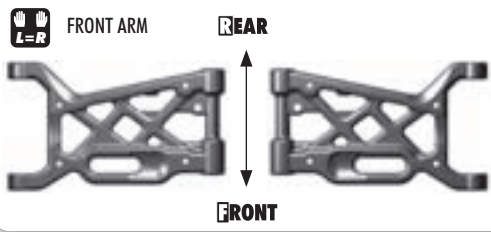

TIP If the suspension arms do not move freely, use a HUDY Arm Reamer resize the holes.

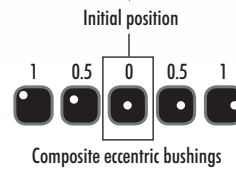
 (HUDY #107634)

All possible mounting alternatives of eccentric bushings

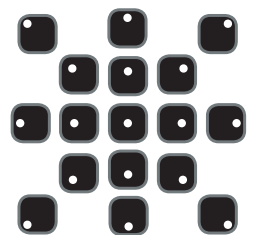

Eccentric bushings have two different offsets from the center.



SET-UP BOOK
KICK UP
ROLL CENTER
DOWNSTOP
WHEELBASE
TRACK WIDTH

The new XRAY alu front lower suspension holders provide even greater range of adjustment for the front suspension. Using different combinations of eccentric bushings, fine adjustment of front kick-up, roll-center, and front track-width can be obtained. For more information about the influence of kick-up, front track-width, and roll centers on car handling, please refer to HUDY Off-Road Set-up Book (#209099).

KICK-UP		
FF	FR	(°)
		= 10°
		= 9°
		= 11°
		= 9°
		= 10°
		= 11°
		= 10°
		= 11°
		= 12°

TRACK WIDTH		
FF	FR	(mm)
		= 308
		= 306
		= 310

ROLL-CENTER		
FF	FR	(mm)
		= 1
		= 0
		= -1

TOTAL CASTER = C-HUB CASTER + KICK UP						
C-Hub Caster	KICK-UP					
	8°	9°	10°	11°	12°	
10°	18°	19°	20°	21°	22°	
12°	20°	21°	22°	23°	24°	
14°	22°	23°	24°	25°	26°	

The tables below describe the amounts of kick-up, front track-width change depending on the combinations of eccentric bushings used with 0 and 1mm, 1° off set. The 0.5mm, 0.5° represent the half change.

Example:



Total caster is the angle that the C-hub is to the flat chassis bottom. Caster is affected not only by front kick-up but also by the C-hub caster. The combination of both represents the total caster angle. The XRAY XB9 includes a 10° caster block as stock, but 12° and 14° C-hub caster blocks can be purchased as options.

FRONT SUSPENSION



901312
SB M3x12

2x
L=R

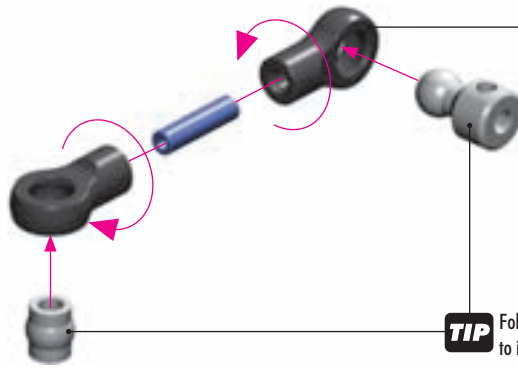

TIP Follow the TECH TIP on page 5 to install the pivot balls

901303
SB M3x3

901305
SB M3x5



902318
SH M3x18



903308
SFH M3x8

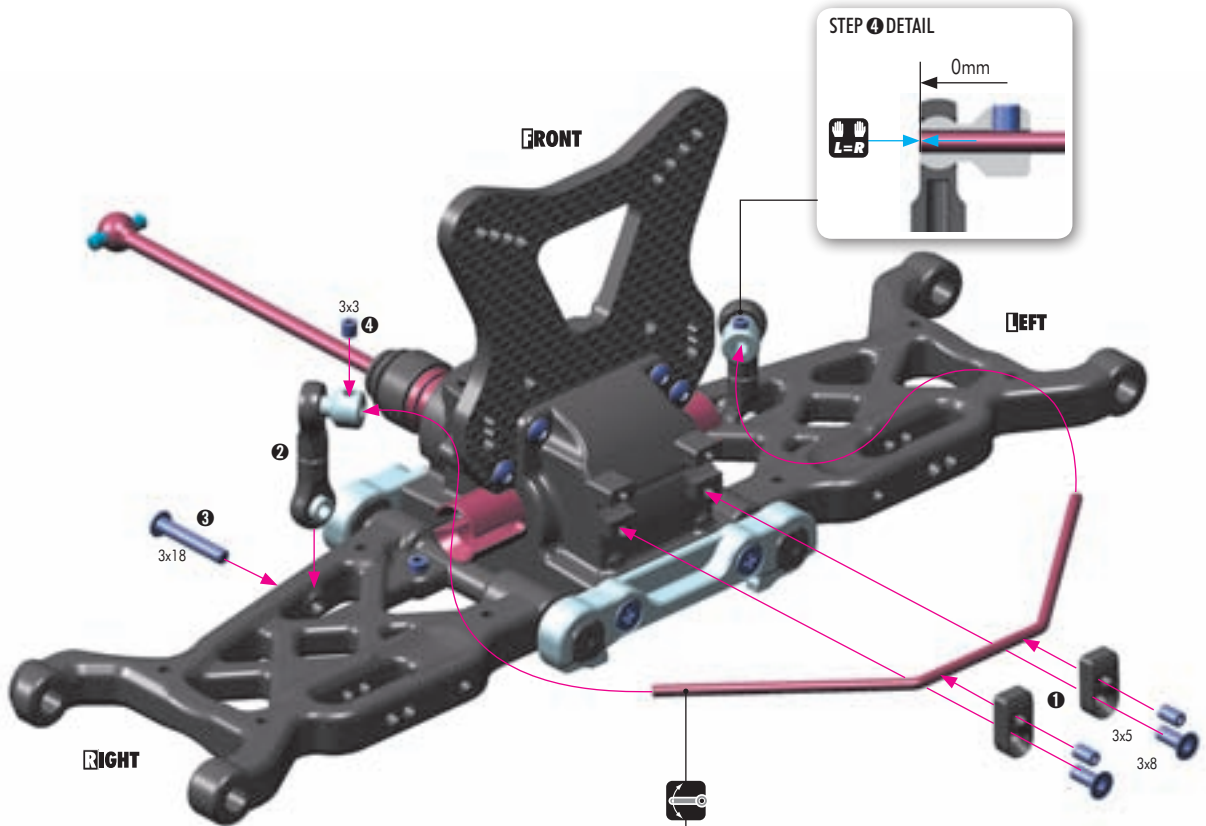

STEP 4 DETAIL

0mm

L=R

LEFT

RIGHT

3x3

2

3

3x18

1

3x5

3x8

DETAIL

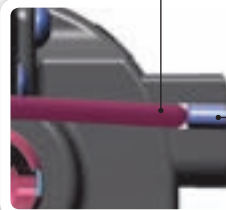

Step 1
Loosen the 3x5 setscrew if the anti-roll bar does not turn freely

DETAIL

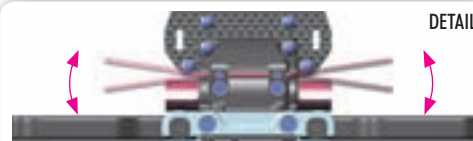

Step 1 check for free movement

SET-UP BOOK

ANTI-ROLL BAR

6. FRONT SUSPENSION

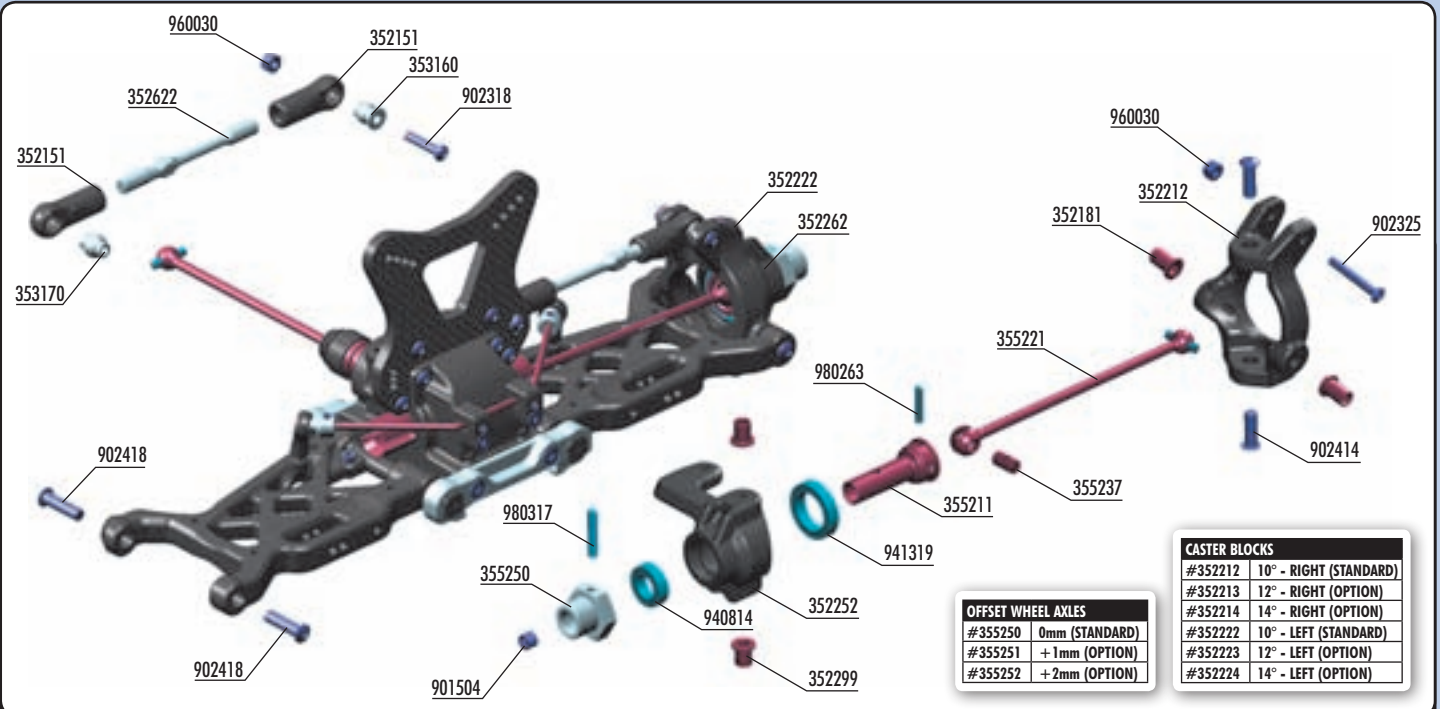

OFFSET WHEEL AXLES	
#355250	0mm (STANDARD)
#355251	+ 1mm (OPTION)
#355252	+ 2mm (OPTION)

CASTER BLOCKS	
#352212	10° - RIGHT (STANDARD)
#352213	12° - RIGHT (OPTION)
#352214	14° - RIGHT (OPTION)
#352222	10° - LEFT (STANDARD)
#352223	12° - LEFT (OPTION)
#352224	14° - LEFT (OPTION)

BAG

06

- 35 2151 FRONT UPPER ARM BALL JOINT (2)
- 35 2181 STEEL ARM BUSHING (2)
- 35 2212 COMPOSITE CASTER BLOCK 10° RIGHT
- 35 2222 COMPOSITE CASTER BLOCK 10° LEFT
- 35 2252 COMPOSITE STEERING BLOCK RIGHT
- 35 2262 COMPOSITE STEERING BLOCK LEFT
- 35 2299 STEEL STEERING BUSHING (2)
- 35 2622 ALU ADJ. TURNBUCKLE M5 L/R 58 MM - SWISS 7075 T6 (2)
- 35 3160 MOUNTING BALL 6.8 (4)
- 35 3170 PIVOT BALL 6.8 (4)
- 35 5211 CVD DRIVE AXLE - HUDY SPRING STEEL™
- 35 5221 CVD UNIVERSAL DRIVE SHAFT - HUDY SPRING STEEL™

- 35 5237 CVD DRIVE SHAFT COUPLING - HUDY SPRING STEEL™
- 35 5250 ALU WHEEL AXLE - HARD COATED (2)
- 90 1504 HEX SCREW SB M5x4 (10)
- 90 2318 HEX SCREW SH M3x18 (10)
- 90 2325 HEX SCREW SH M3x25 (10)
- 90 2414 HEX SCREW SH M4x14 (10)
- 90 2418 HEX SCREW SH M4x18 (10)
- 94 0814 HIGH-SPEED BALL-BEARING 8x14x4 BLUE COVERED (2)
- 94 1319 HIGH-SPEED BALL-BEARING 13x19x4 BLUE COVERED (2)
- 96 0030 NUT M3 (10)
- 98 0263 PIN 2.5x13 (10)
- 98 0317 PIN 3x17 (10)

- 901504 SB M5x4
- 980263 P 2.5x13
- 941319 BB 13x19x4
- 940814 BB 8x14x4
- 902414 SH M4x14
- 980317 P 3x17

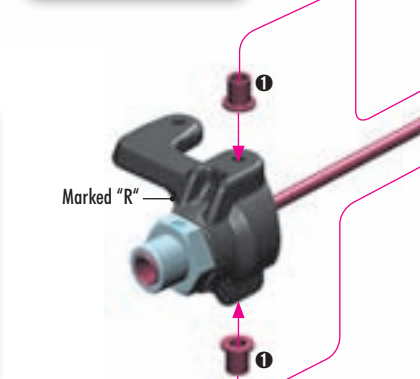
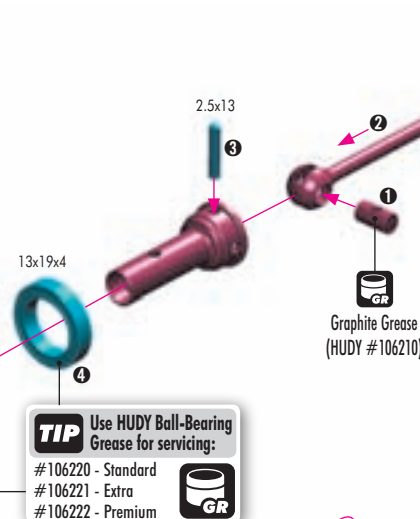
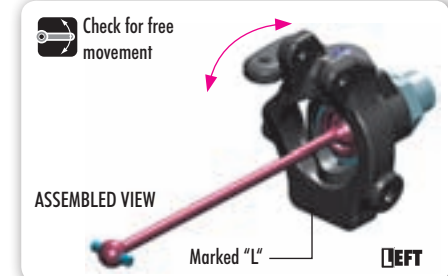
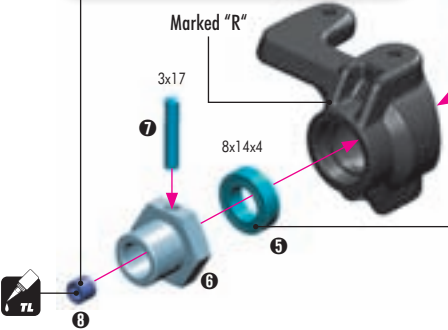

DO NOT OVERTIGHTEN

DO NOT OVERTIGHTEN

The standard caster block features 10° caster angle and together with the 10° angle of the chassis creates a total 20° caster.

SET-UP BOOK
CASTER TRACK WIDTH

FRONT SUSPENSION



902418
SH M4x18

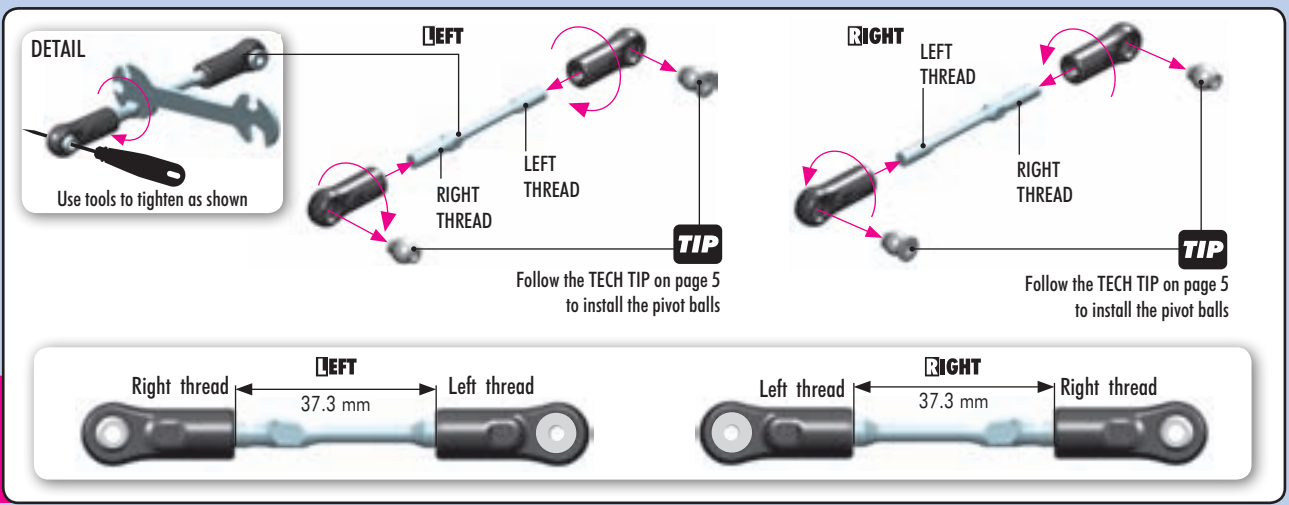
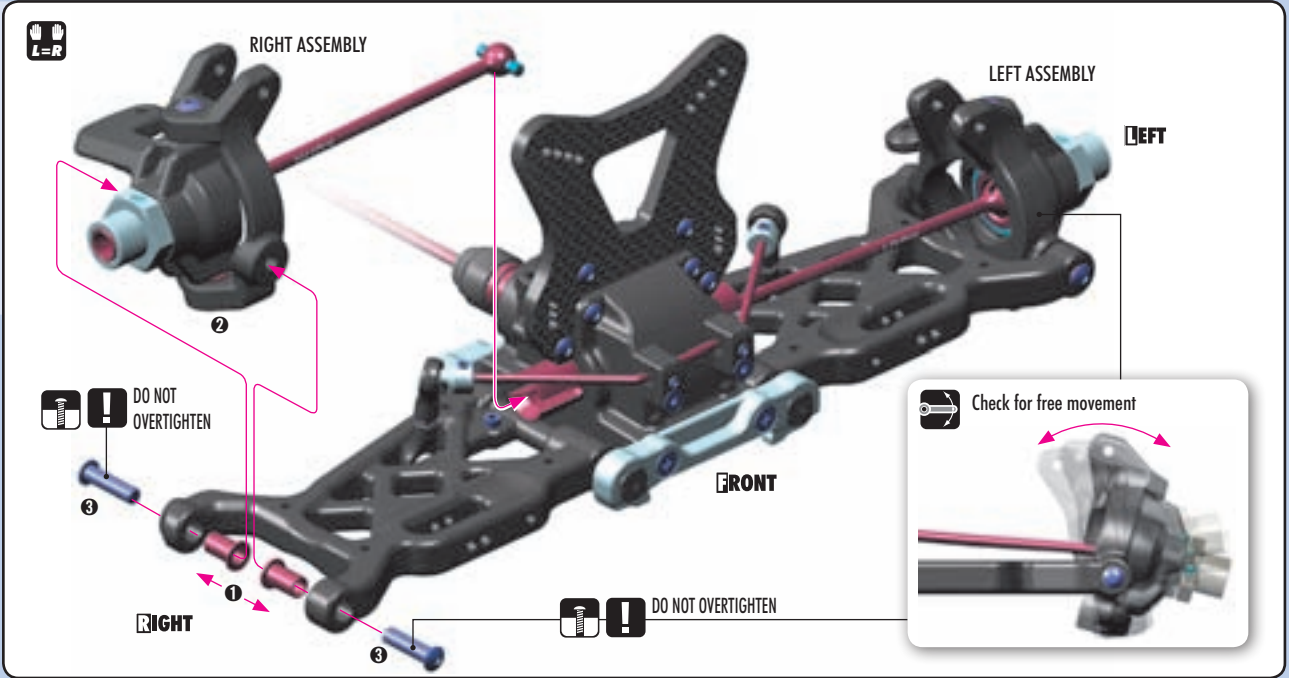

SET-UP BOOK

CAMBER

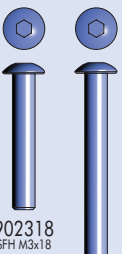

902318
SFH M3x18

902325
SH M3x25



960030
N M3

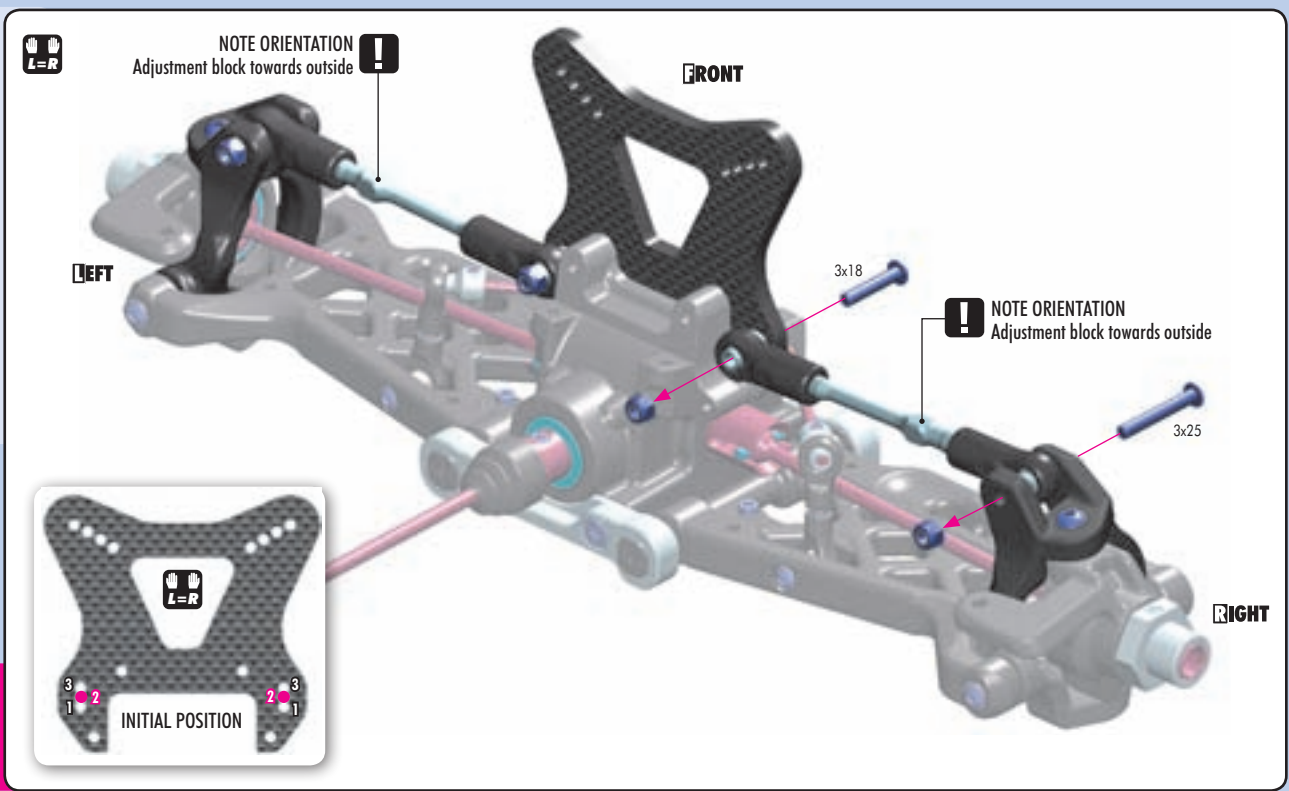

SET-UP BOOK

ROLL CENTER

FRONT & REAR ASSEMBLY

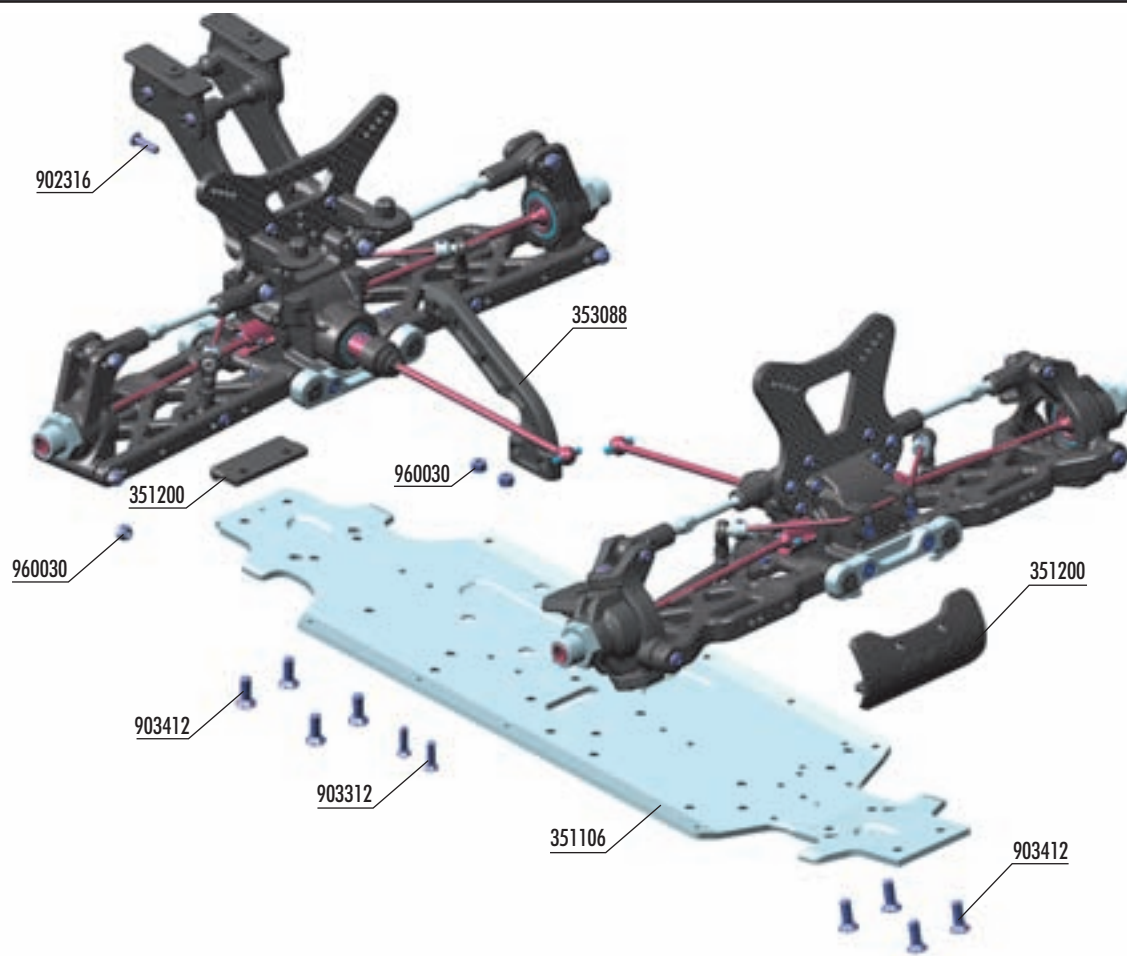

BAG

06

35 1106 XB9 ALU CHASSIS - HARDCOATED SWISS 7075 T6 (3MM)
 35 1200 FRONT & REAR BUMPER - V2
 35 3088 COMPOSITE REAR BRACE - V2

90 2316 HEX SCREW SH M3x16 (10)
 90 3312 HEX SCREW SFH M3x12 (10)
 90 3412 HEX SCREW SFH M4x12 (10)
 96 0030 NUT M3 (10)



903412
 SFH M4x12

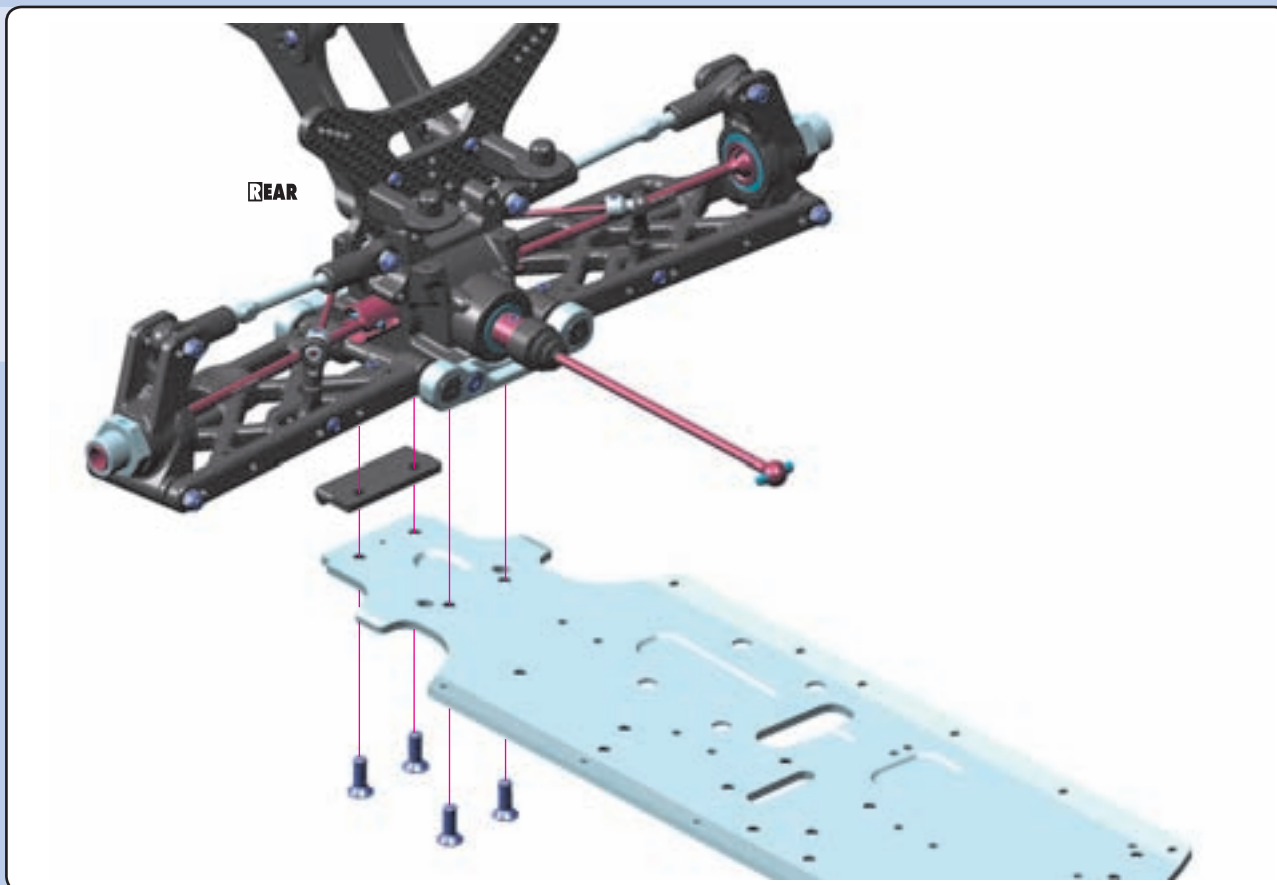

FRONT & REAR ASSEMBLY



902316
SH M3x16



903312
SFH M3x12



960030
N M3

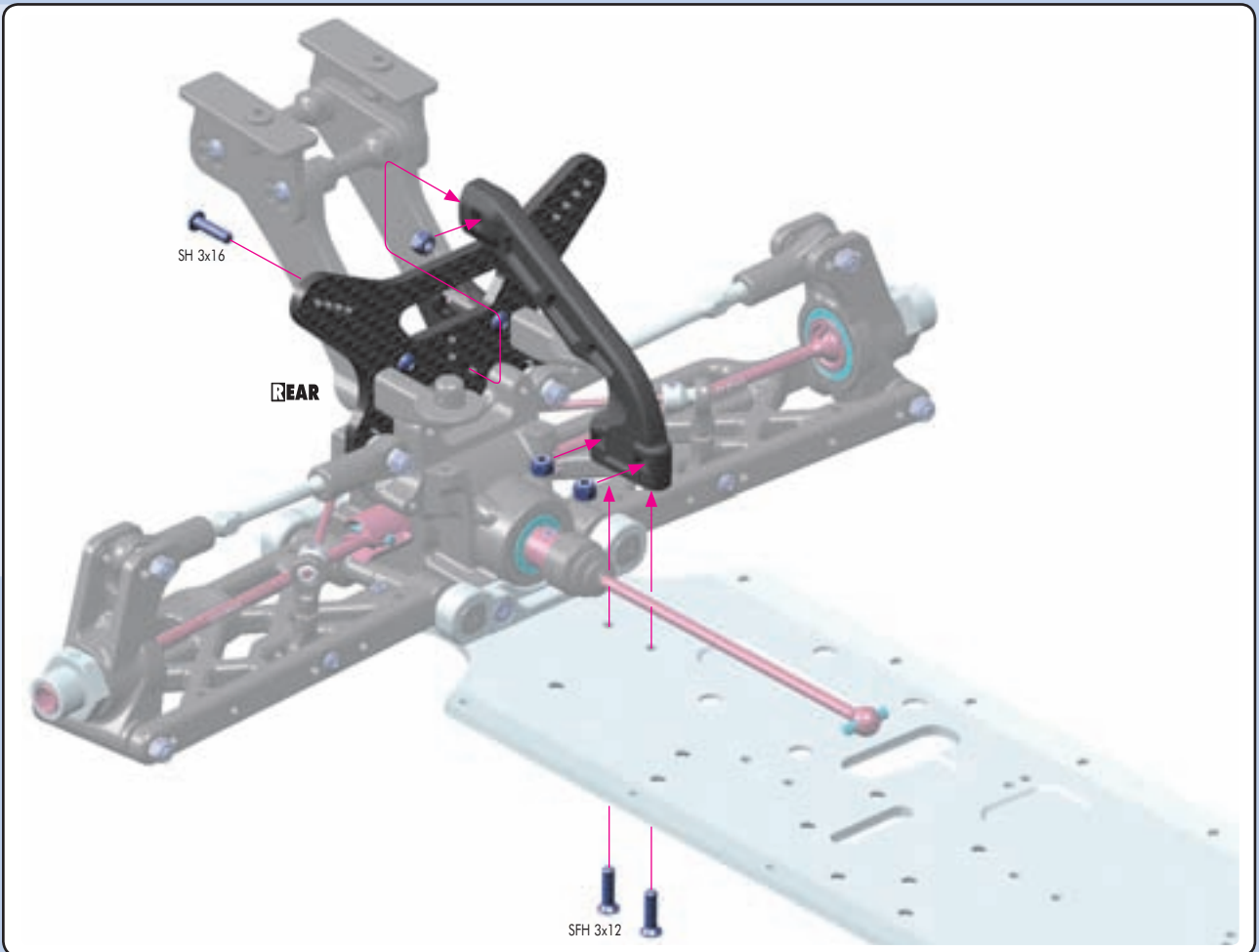

903412
SFH M4x12

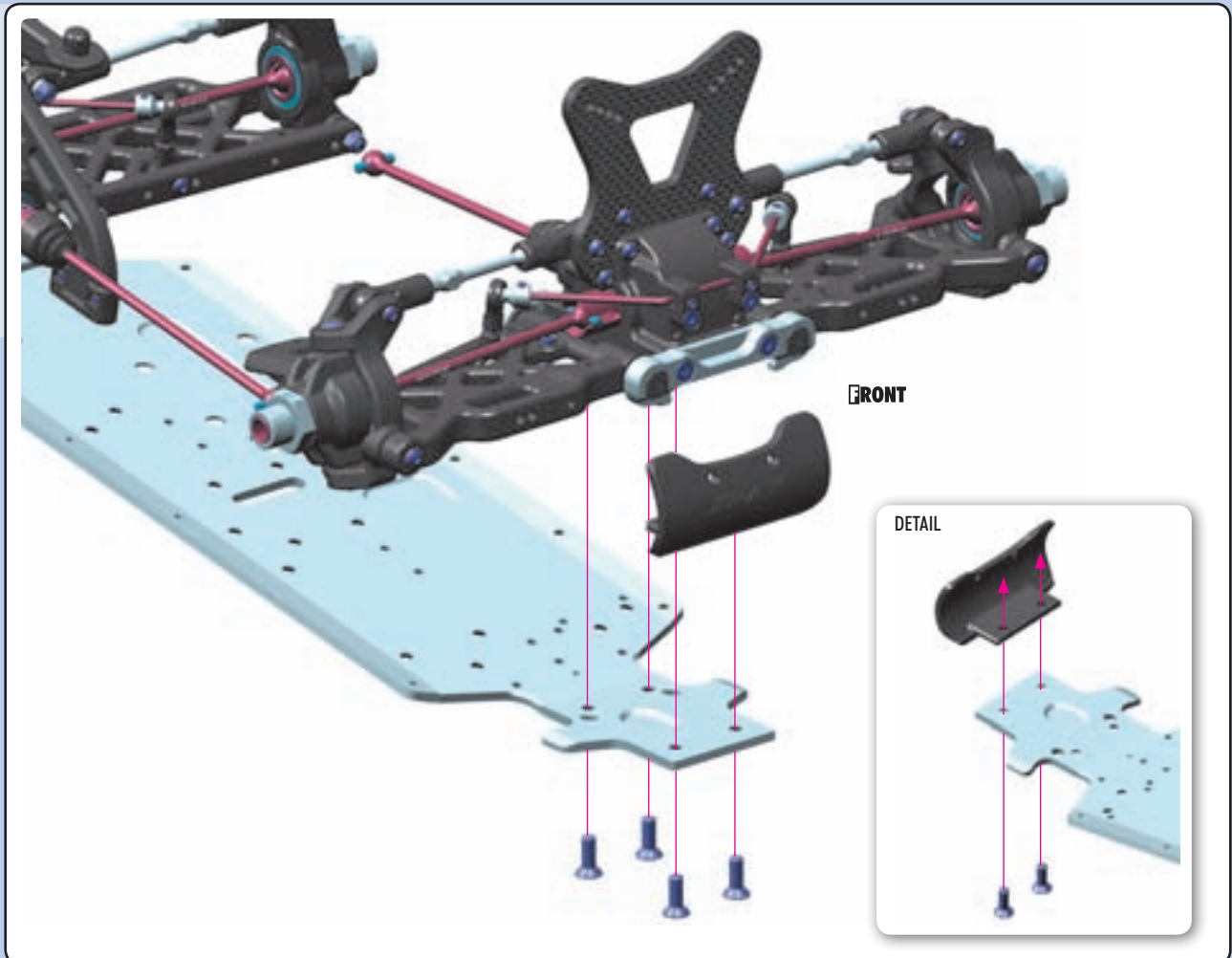

7. STEERING

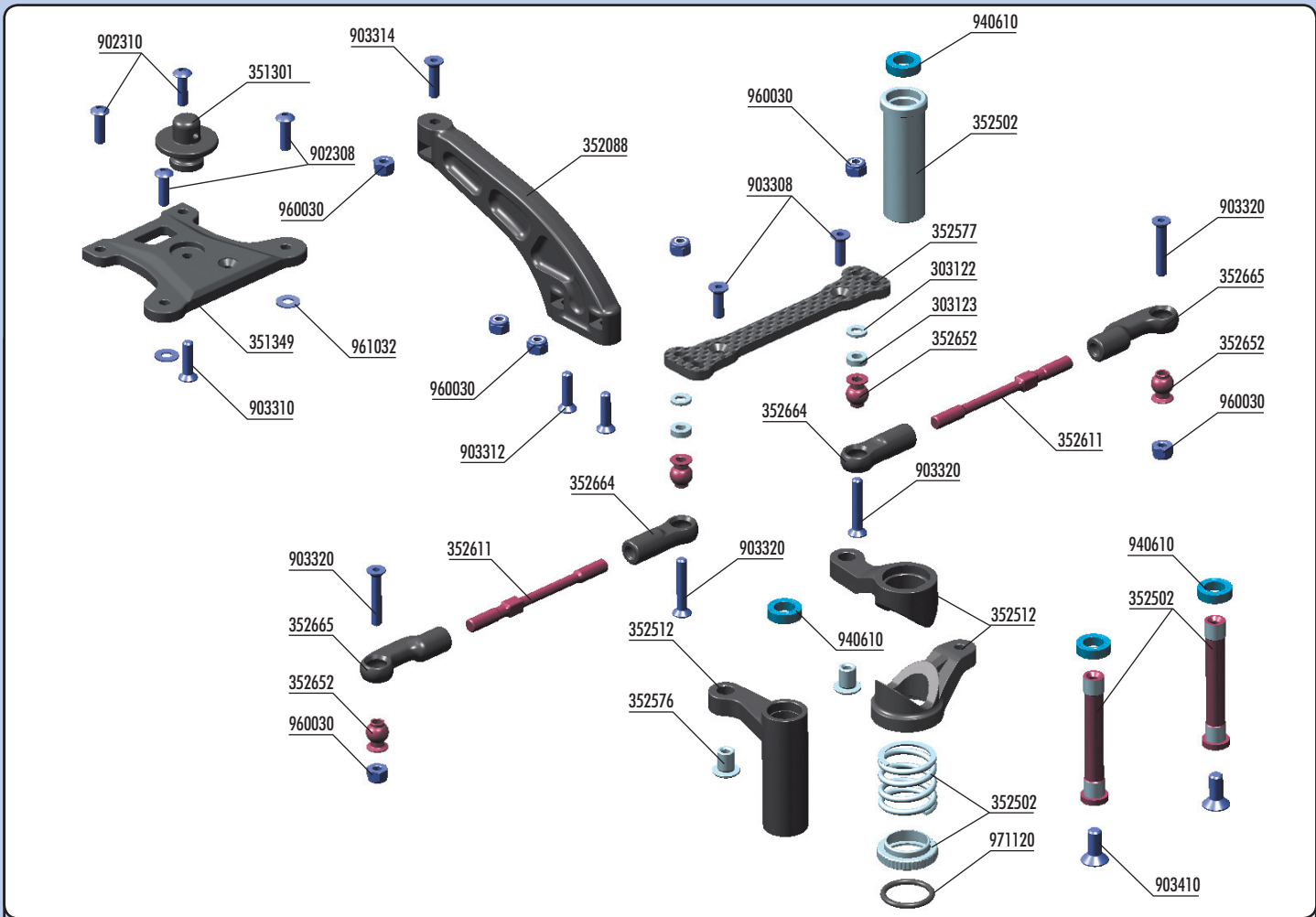

BAG

07

- | | | | |
|---------|--|---------|---|
| 30 3122 | ALU SHIM 3x6x1.0MM (10) | 90 2308 | HEX SCREW SH M3x8 (10) |
| 30 3123 | ALU SHIM 3x6x2.0MM (10) | 90 2310 | HEX SCREW SH M3x10 (10) |
| 35 1301 | BODY POSTS | 90 3308 | HEX SCREW SFH M3x8 (10) |
| 35 1349 | COMPOSITE UPPER PLATE | 90 3310 | HEX SCREW SFH M3x10 (10) |
| 35 2088 | XB9 COMPOSITE FRONT BRACE | 90 3312 | HEX SCREW SFH M3x12 (10) |
| 35 2502 | XB9 SERVO SAVER COMPLETE SET | 90 3314 | HEX SCREW SFH M3x14 (10) |
| 35 2512 | XB9 COMPOSITE SERVO SAVER | 90 3320 | HEX SCREW SFH M3x20 (10) |
| 35 2577 | XB9 GRAPHITE STEERING PLATE | 90 3410 | HEX SCREW SFH M4x10 (10) |
| 35 2576 | STEERING PLATE BUSHING (2) | 94 0610 | HIGH-SPEED BALL-BEARING 6x10x3 BLUE COVERED (2) |
| 35 2611 | ADJ. TURNBUCKLE M4 L/R 51 MM - HUDY SPRING STEEL (2) | 96 0030 | NUT M3 (10) |
| 35 2652 | BALL STUD 6.8MM (4) | 96 1032 | WASHER S 3.2 (10) |
| 35 2664 | COMPOSITE STEERING BALL JOINT 6.8MM (2) | 97 1120 | SILICONE O-RING 12x1.6 (10) |
| 35 2665 | COMPOSITE RELIEF STEERING BALL JOINT 6.8MM (2) | | |

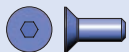

903308
SFH M3x8



940610
BB 6x10x3

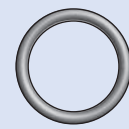

971120
O 12x1.6

SET-UP BOOK

SERVO SAVER

step 1

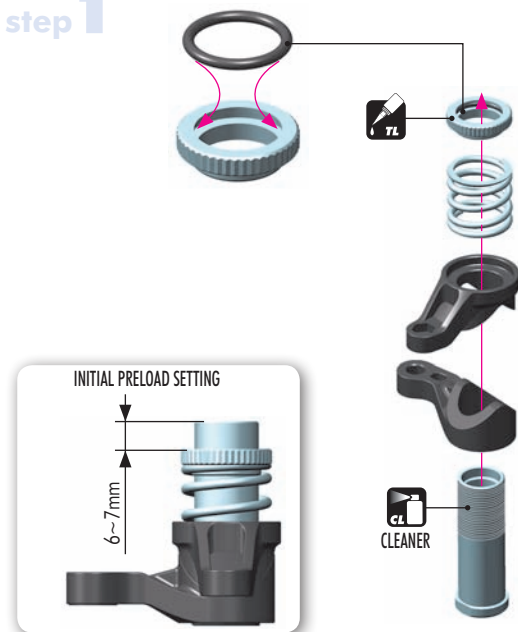



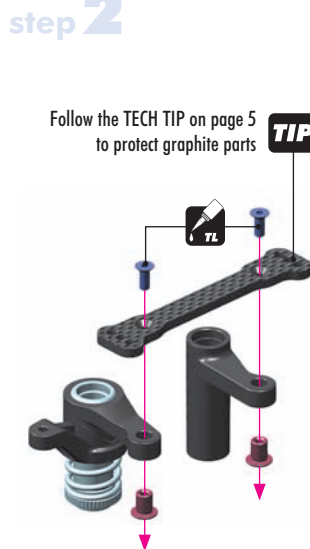

step 2

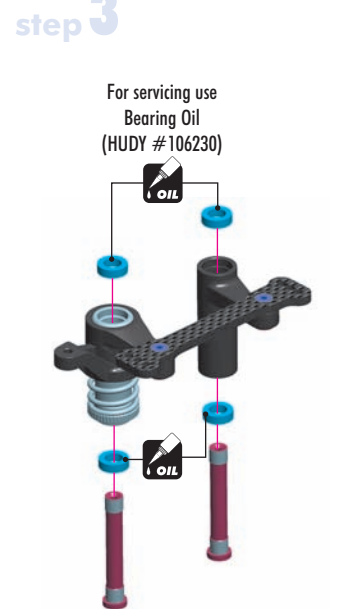

step 3

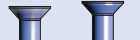
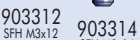

For servicing use
Bearing Oil
(HUDY #106230)

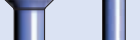
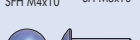
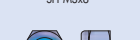
-  903310
SFH M3x10
-  903312
SFH M3x12
-  903314
SFH M3x14
-  903410
SFH M4x10
-  902310
SFH M3x10
-  902308
SH M3x8
-  960030
N M3
-  961032
S 3.2

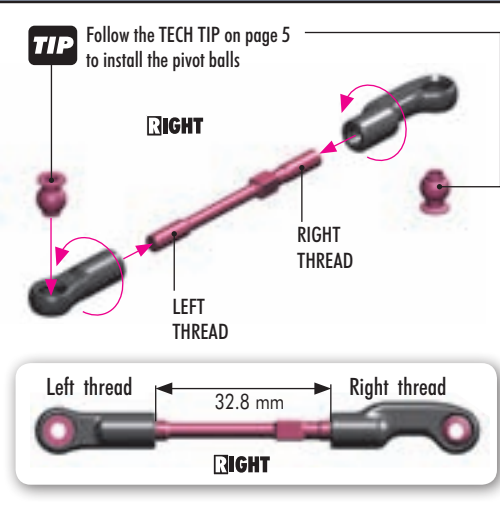
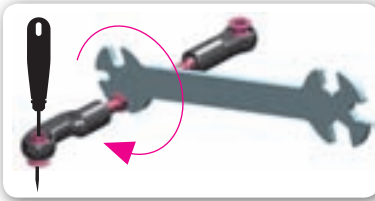
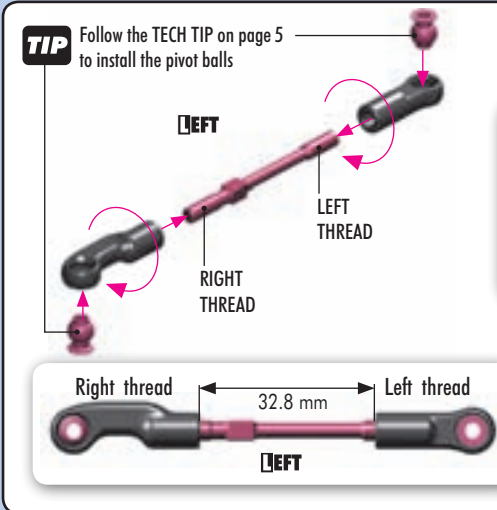
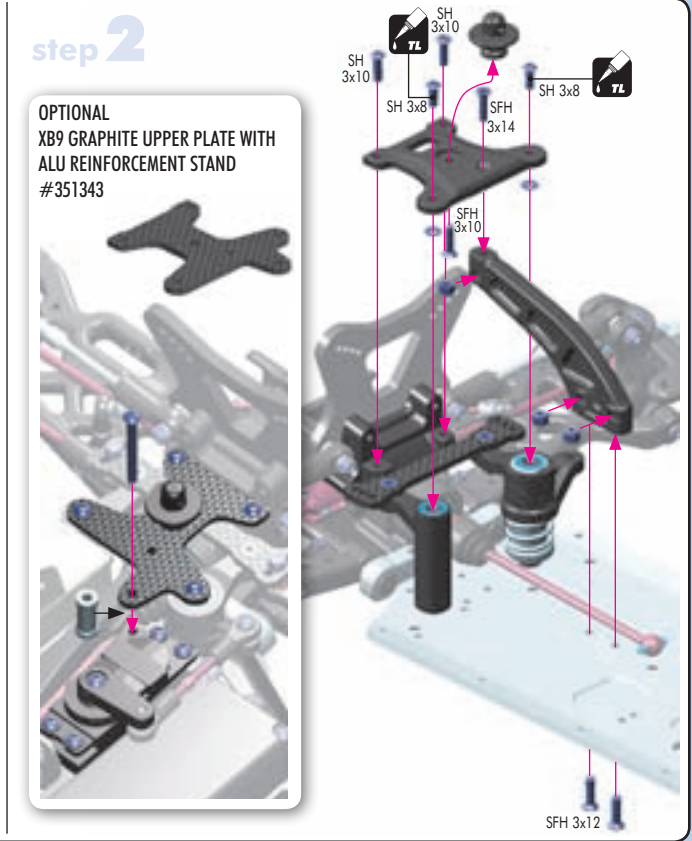
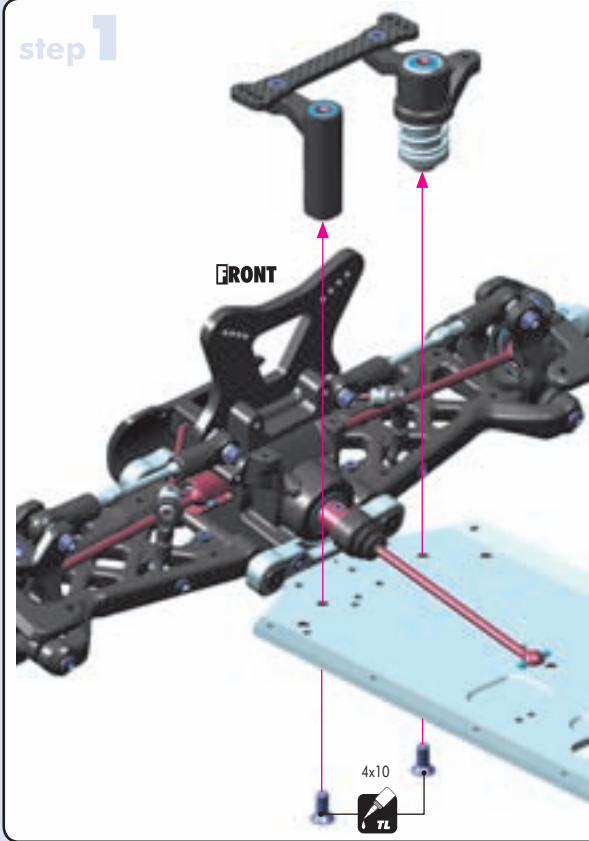

-  303122
SHIM 3x6x1
-  303123
SHIM 3x6x2
-  903320
SFH M3x20
-  960030
N M3

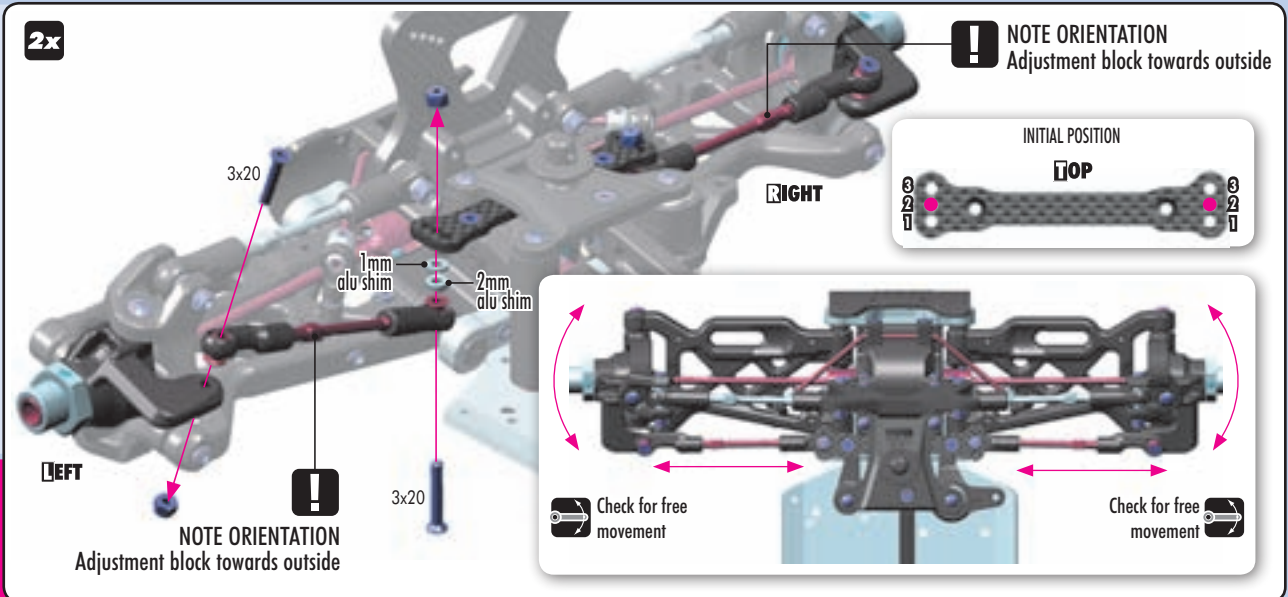

SET-UP BOOK
ACKERMANN
BUMP STEER
TOE-IN

8. CENTER DIFF & BRAKE

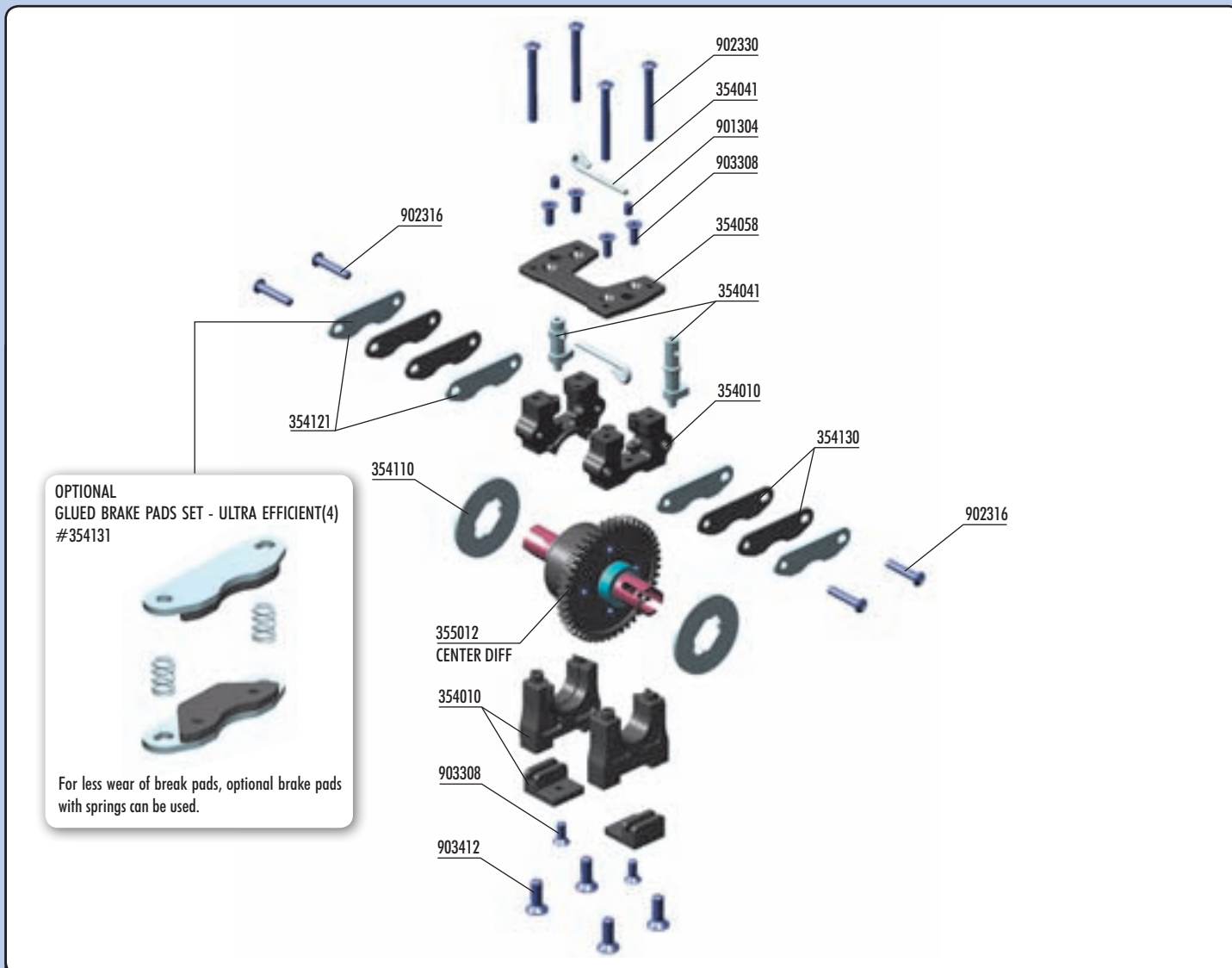

**OPTIONAL
GLUED BRAKE PADS SET - ULTRA EFFICIENT(4)
#354131**

For less wear of brake pads, optional brake pads with springs can be used.



35 4010	CENTER DIFF MOUNTING PLATE - SET	90 1304	HEX SCREW SB M3x4 (10)
35 4041	ALU BRAKE CAM POST & ROD (2+2) HARD COATED	90 2316	HEX SCREW SH M3x16 (10)
35 4058	COMPOSITE CENTER DIFF MOUNTING PLATE	90 2330	HEX SCREW SH M3x30 (10)
35 4110	VENTILATED BRAKE DISK - LASER CUT - PRECISION-GROUND	90 3308	HEX SCREW SFH M3x8 (10)
35 4121	STEEL BRAKE PAD - LASER CUT (4)	90 3412	HEX SCREW SFH M4x12 (10)
35 4130	BRAKE PAD FERODO (4)		



902316
SH M3x16

2x Steel pad
2x Fibre pad (Ferodo™)
2x Fibre pad (Ferodo™)
2x Steel pad
2x Fibre pads together

TIP
Roughen steel plates with sandpaper before gluing fibre pads

TOP ROUND HOLE
NOTE ORIENTATION
BOTTOM OVAL HOLE

ROUND HOLE
NOTE ORIENTATION

OVAL HOLE
NOTE ORIENTATION

DETAIL
Temporarily insert brake disk between pads to set correct gap
0.5 mm

CENTER DIFF & BRAKE

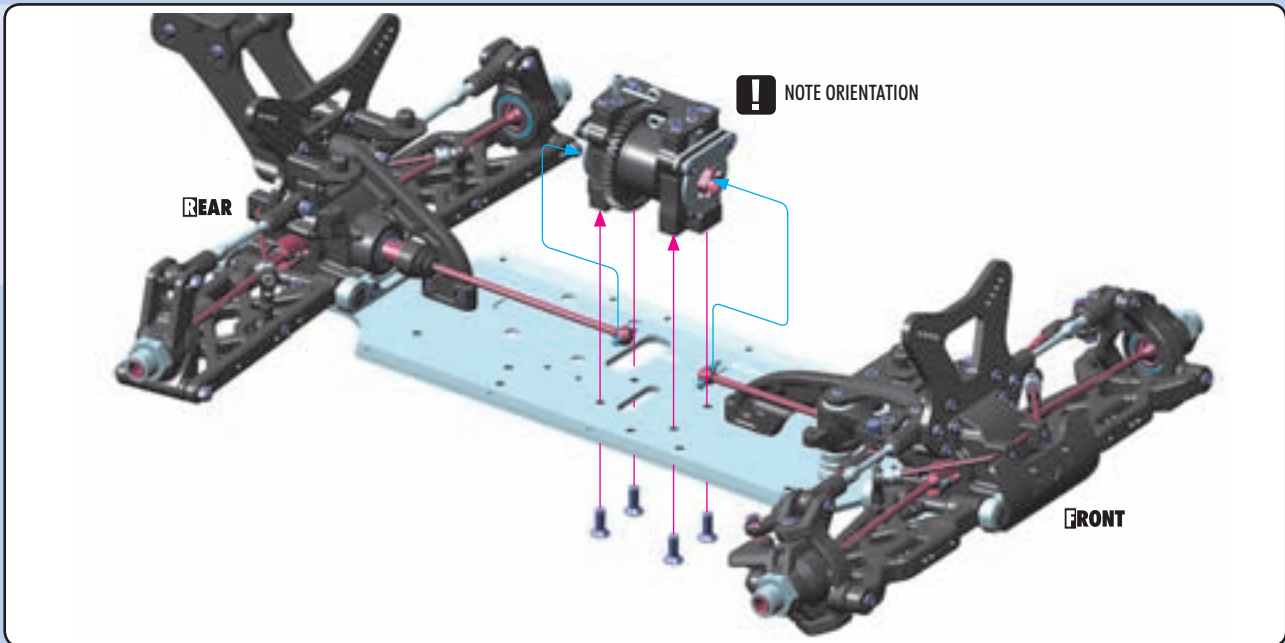
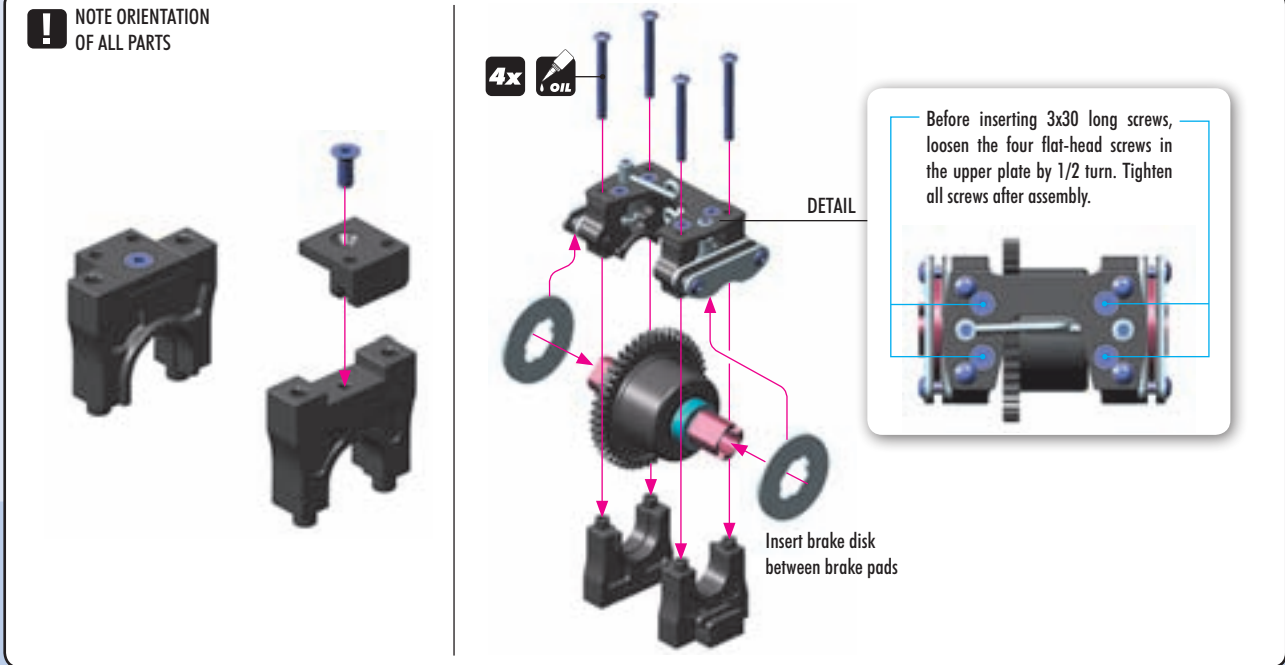
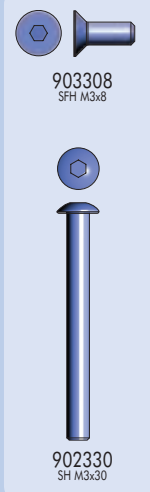
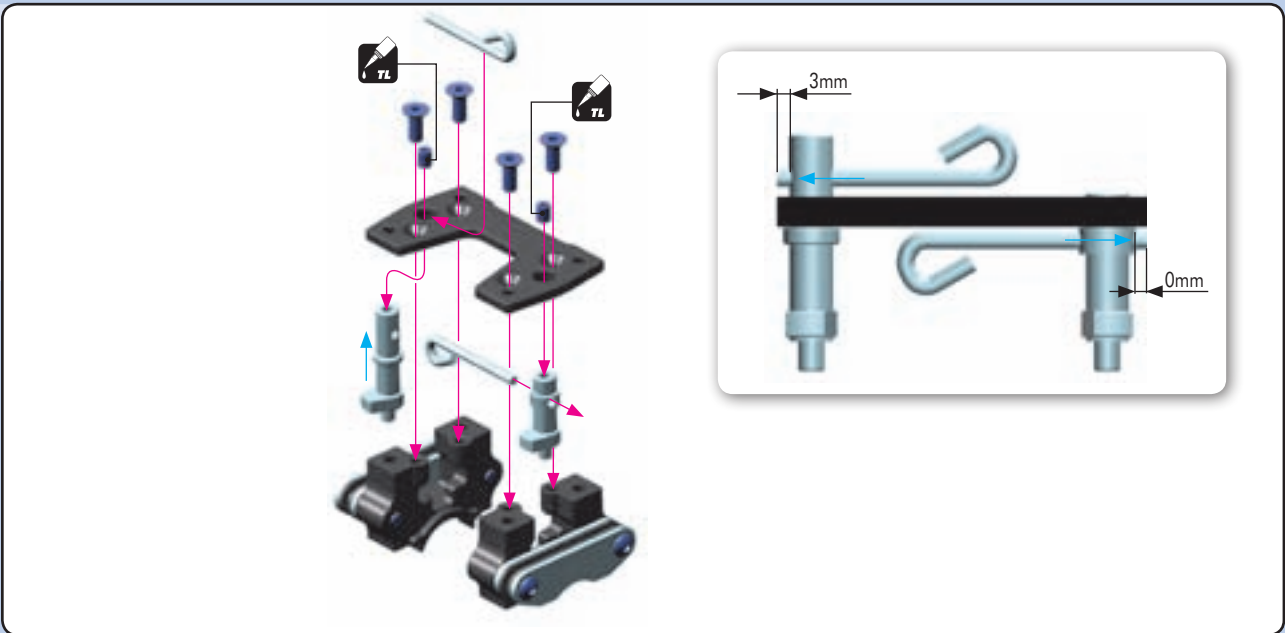

9. FUEL TANK & ENGINE

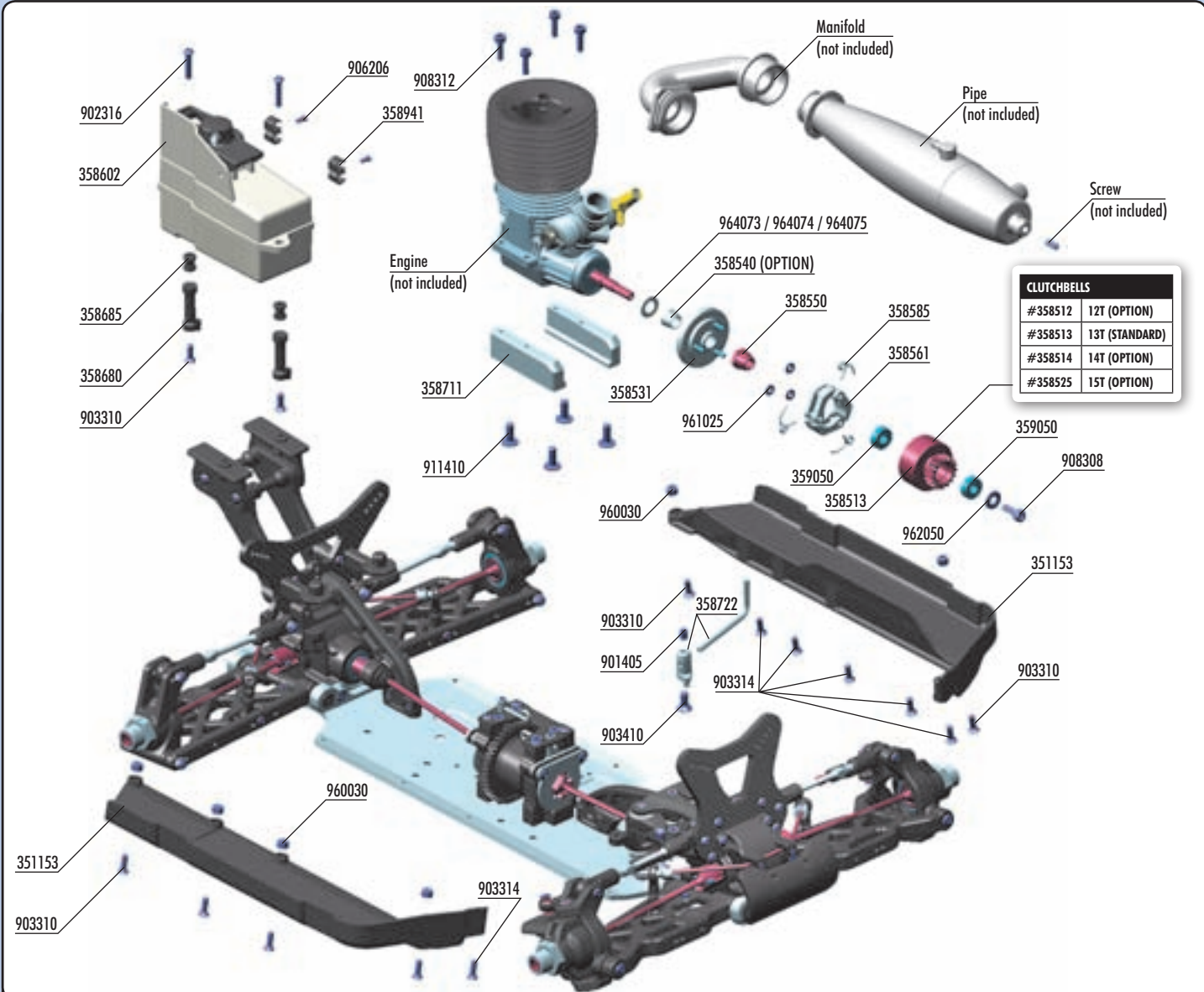



BAG

09

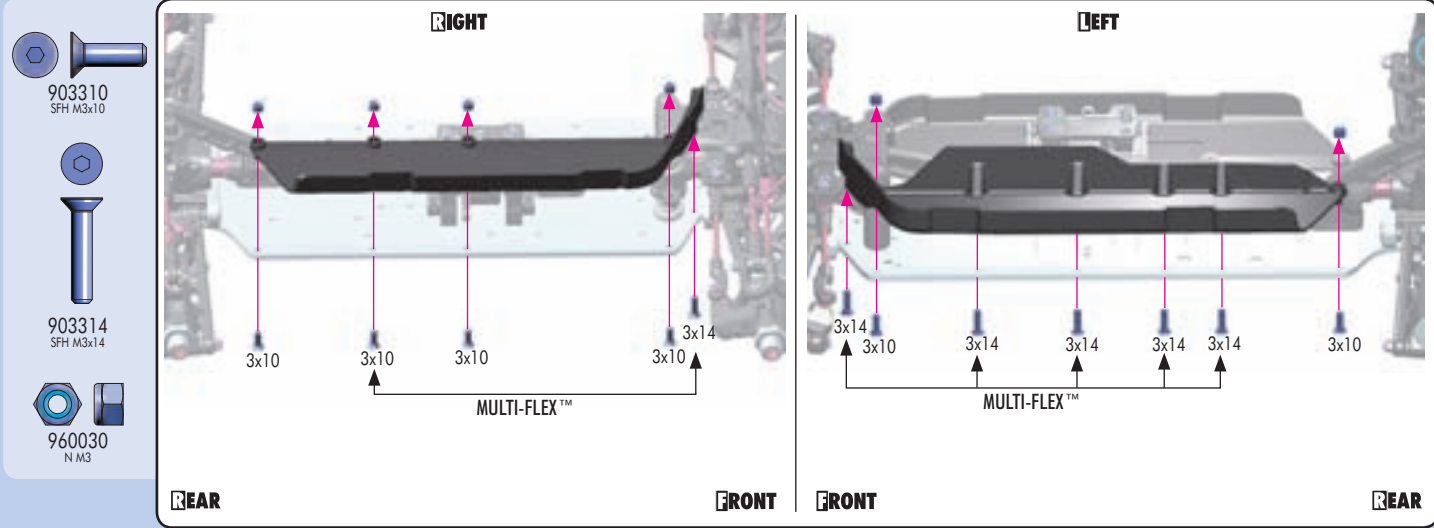
- | | | | | | |
|---------|---|---------|---|---------|---------------------------------|
| 35 1153 | XB9 CHASSIS SIDE GUARDS L+R | 35 8722 | EXHAUST WIRE MOUNT SET - LONG | 90 8312 | HEX SCREW (CAP HEAD) 3x12 (10) |
| 35 8513 | CLUTCH BELL 13T | 35 8941 | COMPOSITE TUBING HOLDER FOR FUEL TANK (2) | 91 1410 | HEX SCREW FLANGED SH M4x10 (10) |
| 35 8531 | FLYWHEEL | | | 96 0030 | NUT M3 (10) |
| 35 8540 | FLYWHEEL COLLAR (OPTION) | 35 9050 | CLUTCH BELL BALL-BEARING 5x10x4 (2) | 96 1025 | WASHER S 2.5 (10) |
| 35 8550 | FLYWHEEL NUT - HUDY SPRING STEEL™ | 90 1405 | HEX SCREW SB M4x5 (10) | 96 2050 | WASHER S 5x10x1.0 (10) |
| 35 8561 | ALU CLUTCH SHOES - LIGHT 1.71g - CNC MACHINED (3) | 90 2316 | HEX SCREW SH M3x16 (10) | 96 4073 | WASHER S 7x10x0.2 (10) |
| 35 8585 | CLUTCH SPRINGS - HARD (3) | 90 3310 | HEX SCREW SFH M3x10 (10) | 96 4074 | WASHER S 7x10x0.3 (10) |
| 35 8602 | FUEL TANK 120CC - SET - V3 | 90 3314 | HEX SCREW SFH M3x14 (10) | 96 4075 | WASHER S 7x10x0.5 (10) |
| 35 8680 | FUEL TANK MOUNTING POST (2) | 90 3410 | HEX SCREW SFH M4x10 (10) | | |
| 35 8685 | FUEL TANK MOUNTING GROMMET (4) | 90 6206 | SCREW PHILLIPS FH 2.2x6 (10) | | |
| 35 8711 | ALU ENGINE MOUNT - CNC MACHINED (L+R) | 90 8308 | HEX SCREW (CAP HEAD) 3x8 (10) | | |



-  908312
SCH M3x12
-  964075
S 7x10x0.5
-  964074
S 7x10x0.3
-  964073
S 7x10x0.2

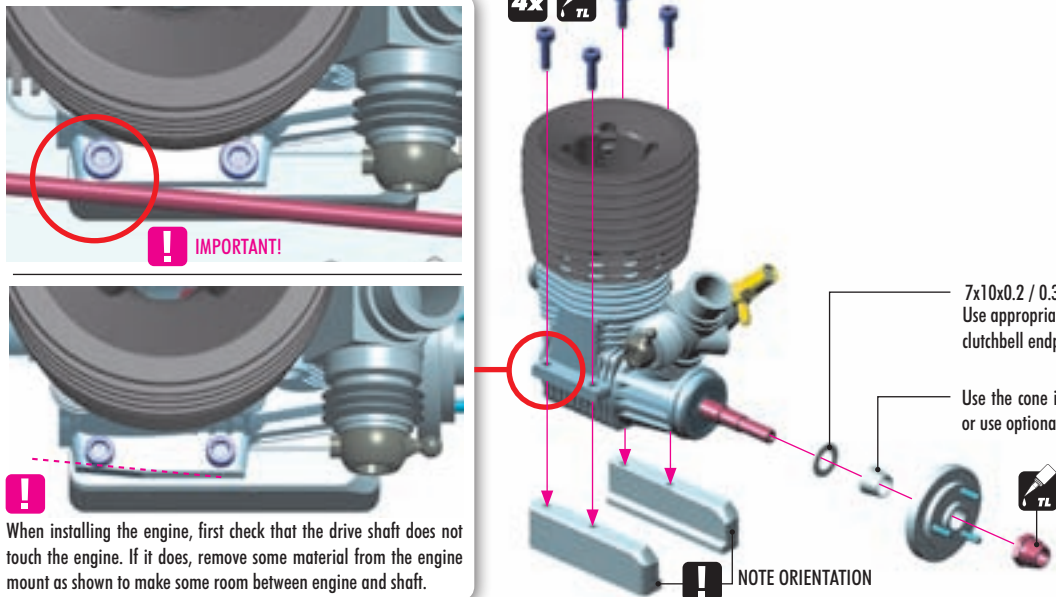

4x 

IMPORTANT!

7x10x0.2 / 0.3 / 0.5
Use appropriate shims to achieve proper clutchbell endplay

Use the cone included with your engine, or use optional XRAY cone #358540

NOTE ORIENTATION

! When installing the engine, first check that the drive shaft does not touch the engine. If it does, remove some material from the engine mount as shown to make some room between engine and shaft.

-  908308
SCH M3x8
-  359050
BB 5x10x4
-  961025
S 2.5
-  962050
S 5x10x1

SET-UP BOOK
CLUTCH SPRINGS
CLUTCH SHOE

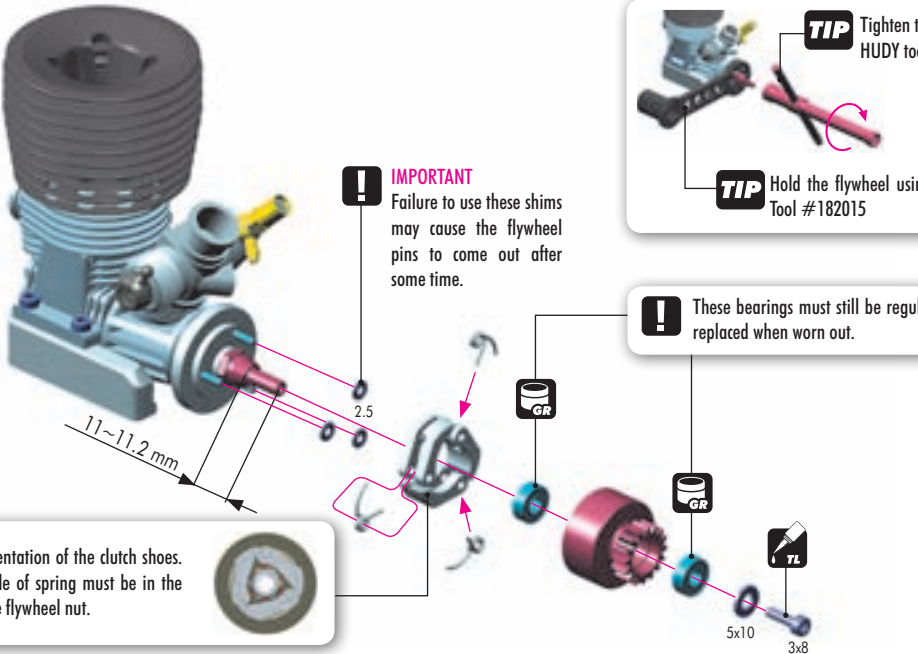

! **IMPORTANT**
Failure to use these shims may cause the flywheel pins to come out after some time.

TIP Tighten the clutch nut using HUDY tool #107581

TIP Hold the flywheel using HUDY Flywheel Tool #182015

! These bearings must still be regularly serviced and replaced when worn out.

Note the orientation of the clutch shoes. The short side of spring must be in the groove of the flywheel nut.

11~11.2mm

2.5

5x10

3x8

-  911410
SHF M4x10

SET-UP BOOK
GEARING
GEAR MESH ADJ.

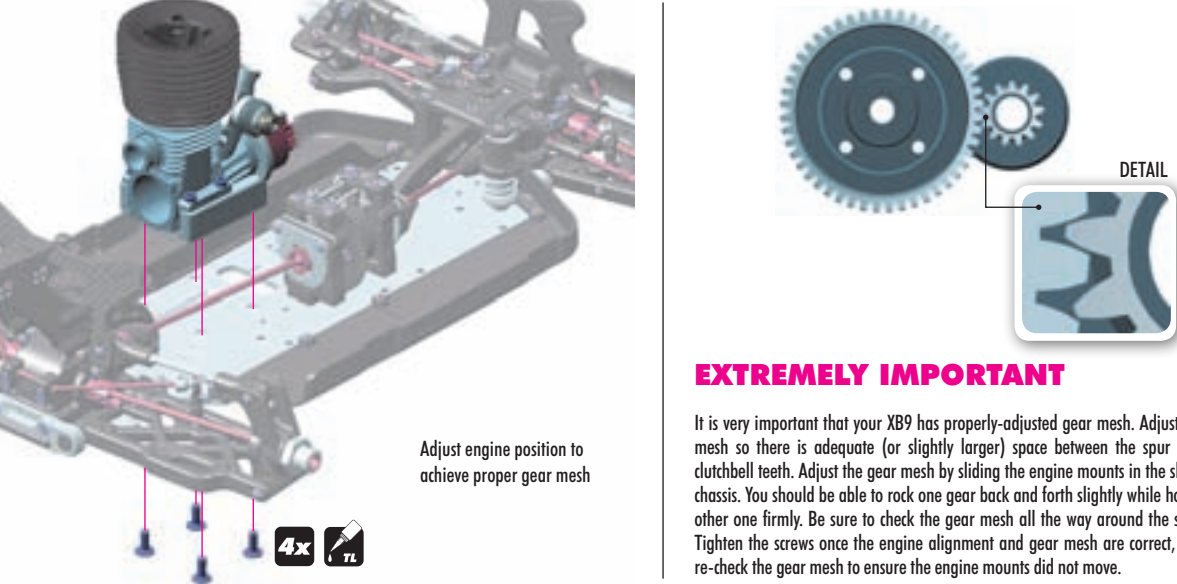

Adjust engine position to achieve proper gear mesh

4x 

EXTREMELY IMPORTANT

It is very important that your XB9 has properly-adjusted gear mesh. Adjust the gear mesh so there is adequate (or slightly larger) space between the spur gear and clutchbell teeth. Adjust the gear mesh by sliding the engine mounts in the slots of the chassis. You should be able to rock one gear back and forth slightly while holding the other one firmly. Be sure to check the gear mesh all the way around the spur gear. Tighten the screws once the engine alignment and gear mesh are correct, and then re-check the gear mesh to ensure the engine mounts did not move.

DETAIL

FUEL TANK & ENGINE

-  902316
SH M3x16
-  903310
SFH M3x10
-  906206
SP 2.2x6
-  907258
SP 2.5x8

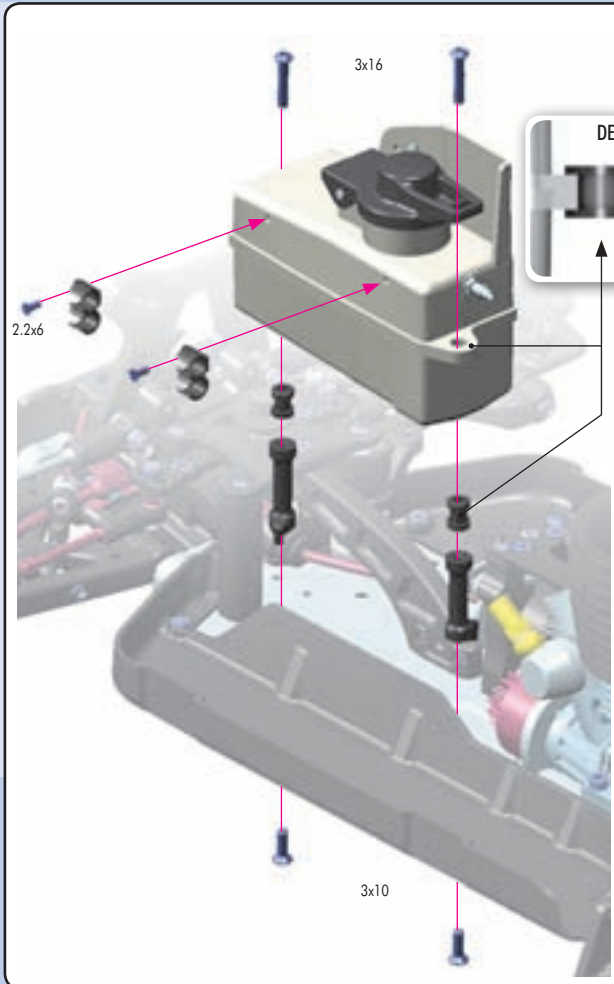

The fuel tank has the bigger fuel volume and includes optional tank inserts for decreasing the volume of the tank. Using the inserts allows you to adjust the volume of fuel inside the tank; this works in conjunction with variables such as fuel filter capacity and/or length of fuel line to ensure you have the legal fuel volume limit for racing.

Tube holders are easily connected to the fuel tank by screws. Using screws is much more secure than using glue to attach the holders to the fuel tank.

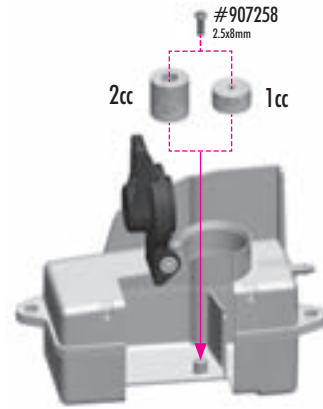

2CC FUEL TANK INSERT

The larger insert decreases the fuel tank volume by 2cc, and is recommended for use when the fuel filter is used.

1CC FUEL TANK INSERT

The smaller insert decreases the fuel tank volume by 1cc.

NOTE ORIENTATION 

NOTE ORIENTATION 

NOTE: The fuel tank insert can be easily mounted to the bottom of the fuel tank using the provided screw, when the fuel tank cap is opened fully.

-  903410
SFH M4x10
-  901405
SB M4x5

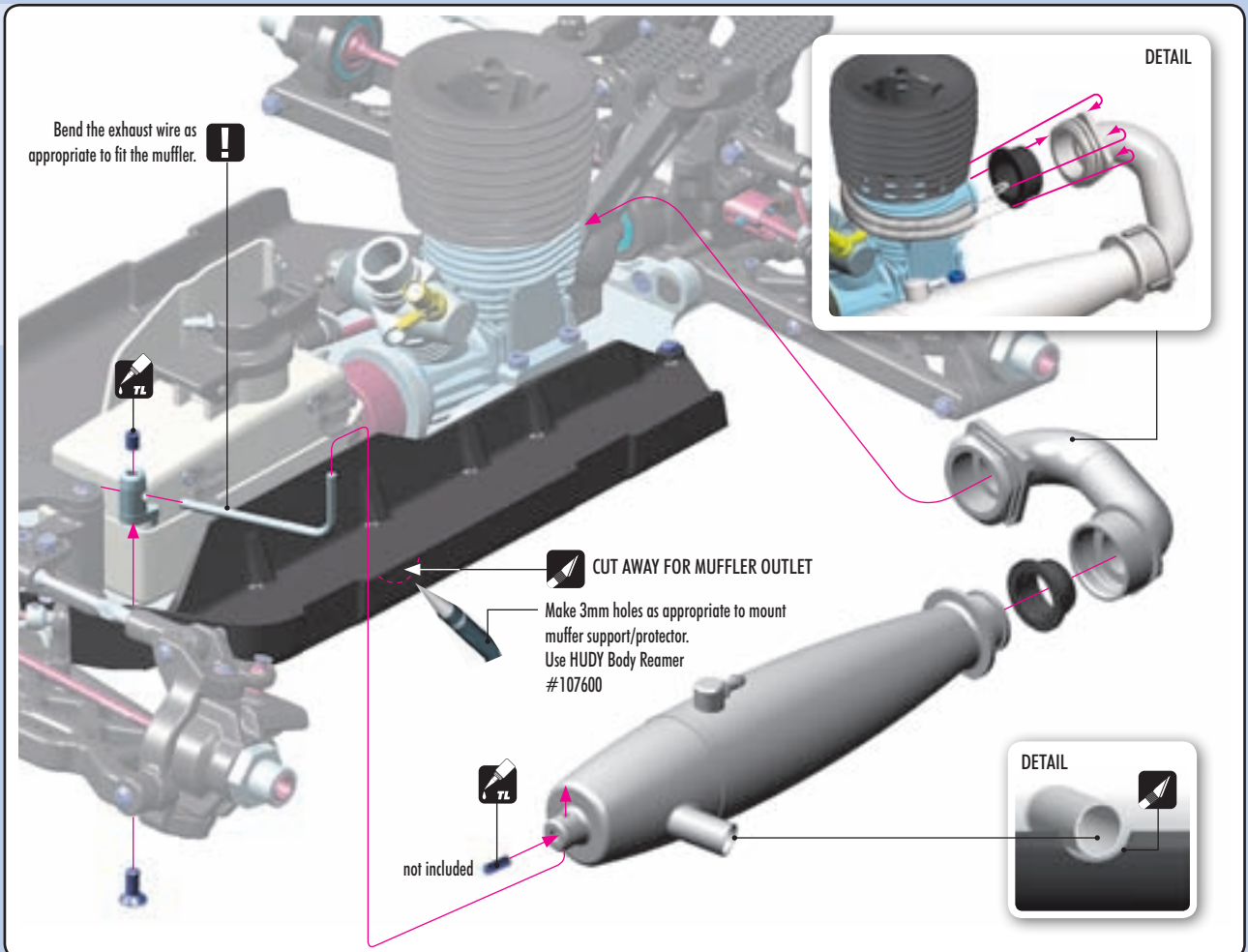

10. RADIO CASE

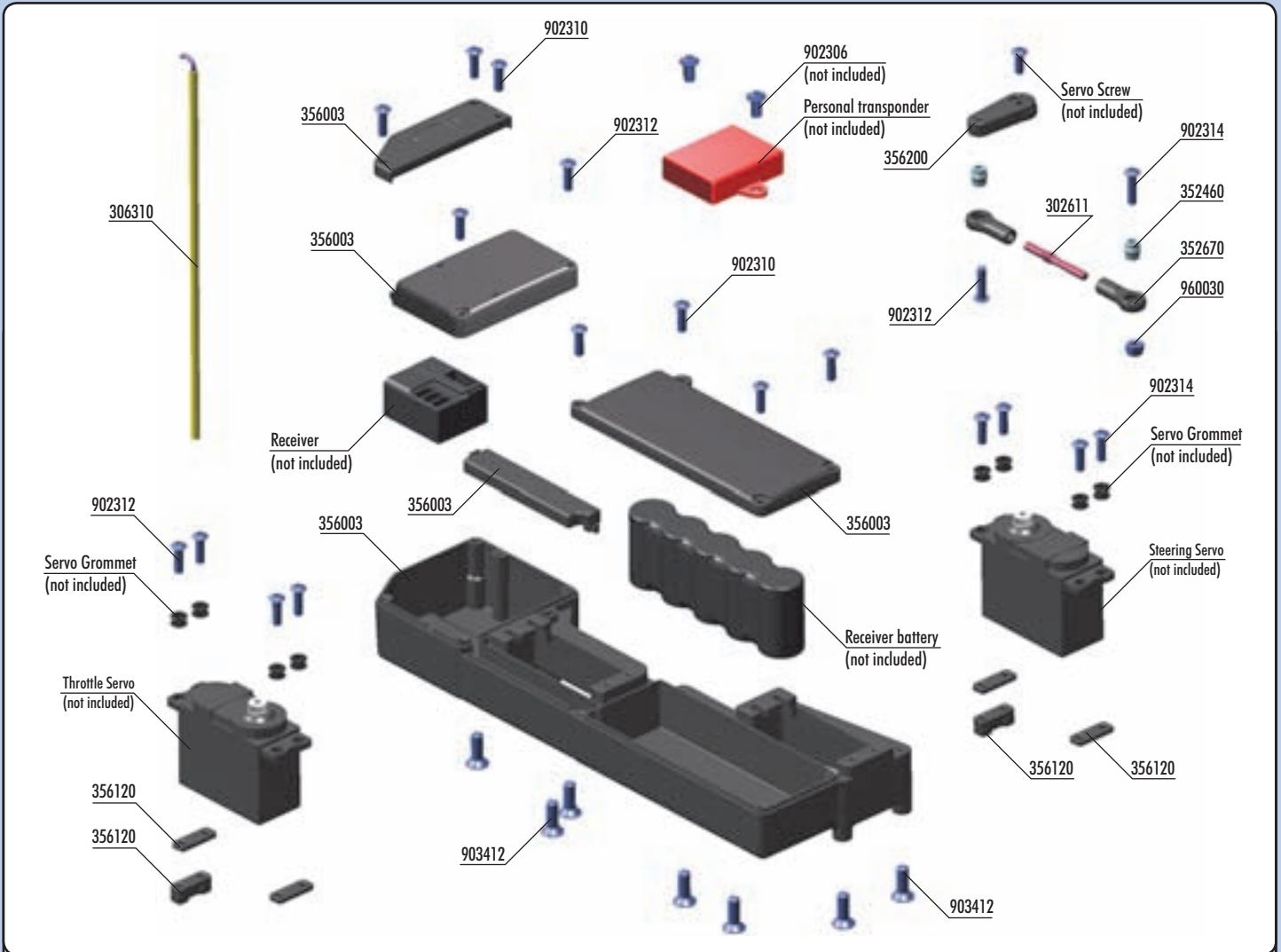

BAG



- 30 2611 ADJ. TURNBUCKLE L/R 35 MM - HUDY SPRING STEEL (2)
- 30 6310 ANTENNA TUBE (2)
- 33 6120 COMPOSITE STEERING SERVO HOLDER - SET - V2
- 35 2460 PIVOT BALL 5.8 (10)
- 35 2670 SERVO BALL JOINT 5.8MM (4)
- 35 6003 XB9 RADIO CASE SET
- 35 6050 BATTERY CABLE WITH SWITCH (OPTION)
- 35 6120 STEERING SERVO MOUNT - SET
- 35 6200 BRAKE/THROTTLE ARMS & STEERING SERVO ARMS - SET

- 38 9135 CONNECTING CABLE RECEIVER/BATT. PACK (OPTION)
- 90 2310 HEX SCREW SH M3x10 (10)
- 90 2312 HEX SCREW SH M3x12 (10)
- 90 2314 HEX SCREW SH M3x14 (10)
- 90 3412 HEX SCREW SFH M4x12 (10)
- 96 0030 NUT M3 (10)



902312
SH M3x12

step 1

Follow the TECH TIP on page 5 to install the pivot balls **TIP**

RIGHT THREAD
LEFT THREAD

TIP Follow the TECH TIP on page 5 to install the pivot balls

Right thread 16 mm Left thread

The length of the linkages varies according to the type of servo.

step 2

NOTE ORIENTATION

USE APPROPRIATE SERVO ARM:

- K - KO Propo, JR, Sanwa, Multiplex
- H - Hitec
- F - Futaba

RADIO CASE



902312
SH M3x12



902314
SH M3x14

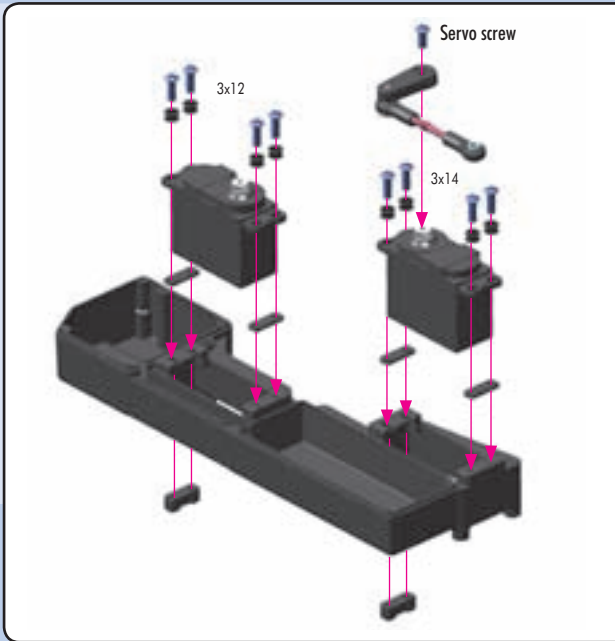

step 1

Plug the connectors into the receiver in Step 2

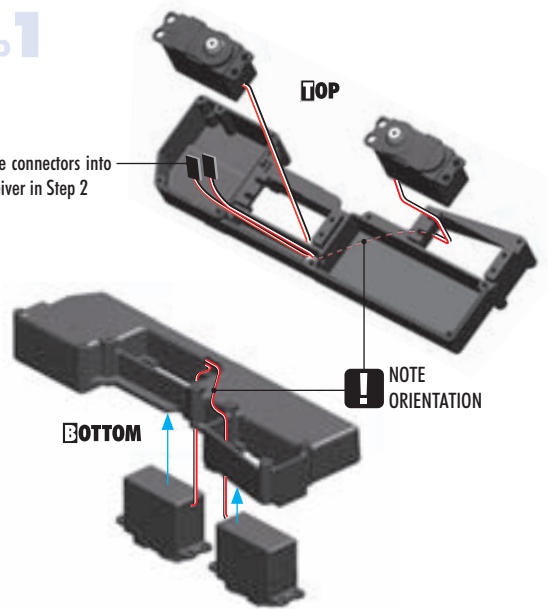

902310
SH M3x10



902312
SH M3x12



907206
SF M2x6

step 2

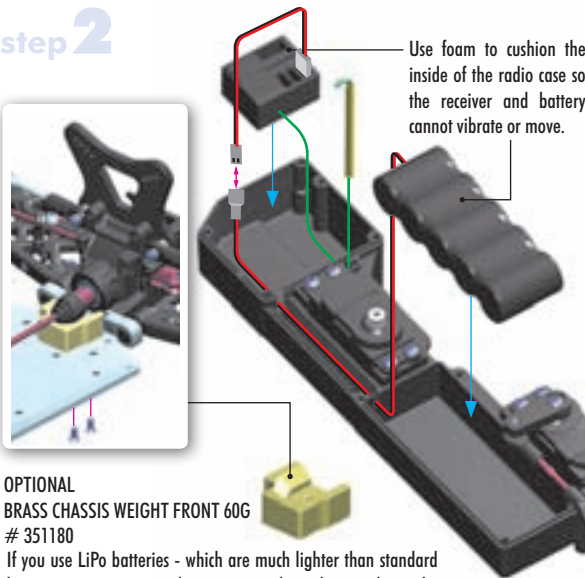

OPTIONAL
BRASS CHASSIS WEIGHT FRONT 60G
351180

If you use LiPo batteries - which are much lighter than standard batteries - we recommend using optional weights to achieve the proper weight balance for the car.

TIP CUT

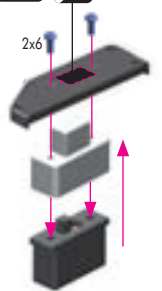

OPTIONAL
SWITCH #356050

When receiver switch is used, use hobby knife to CAREFULLY remove the material from the cover and mount the switch.



903412
SFH M4x12



902314
SH M3x14



960030
N M3

Personal transponder (not included)
902306 Screws (not included)

Personal transponder can be placed on the top of the radio box or inside of the radio box

ALTERNATIVE 1

When the transponder is placed at the top of the radio box, cut out some material from the radio box in order to allow the transponder wire to come inside.

ALTERNATIVE 2

Place the transponder inside of the radio box by using double side tape.

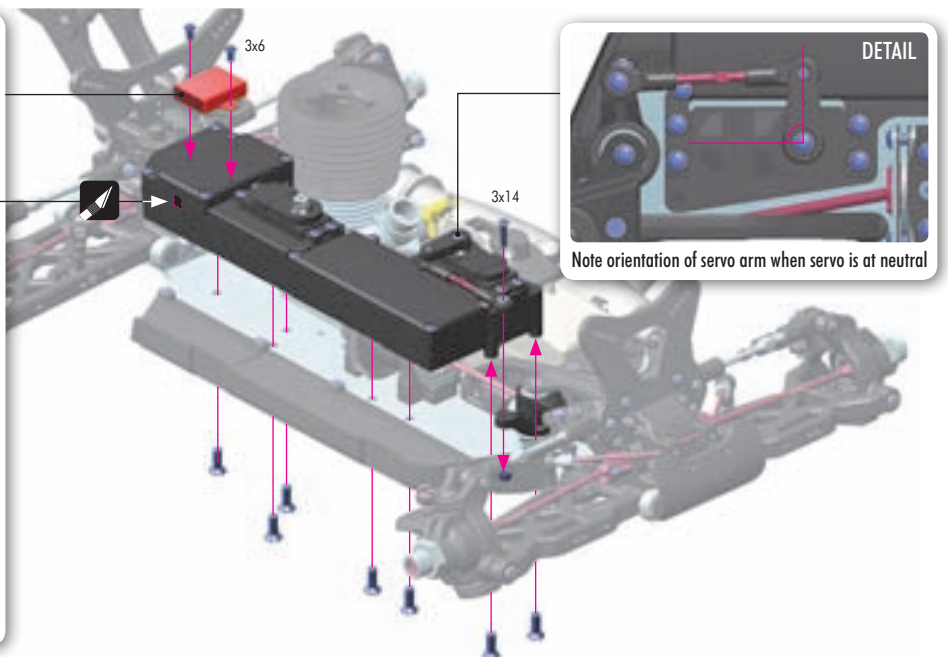

Note orientation of servo arm when servo is at neutral

11. SHOCK ABSORBERS

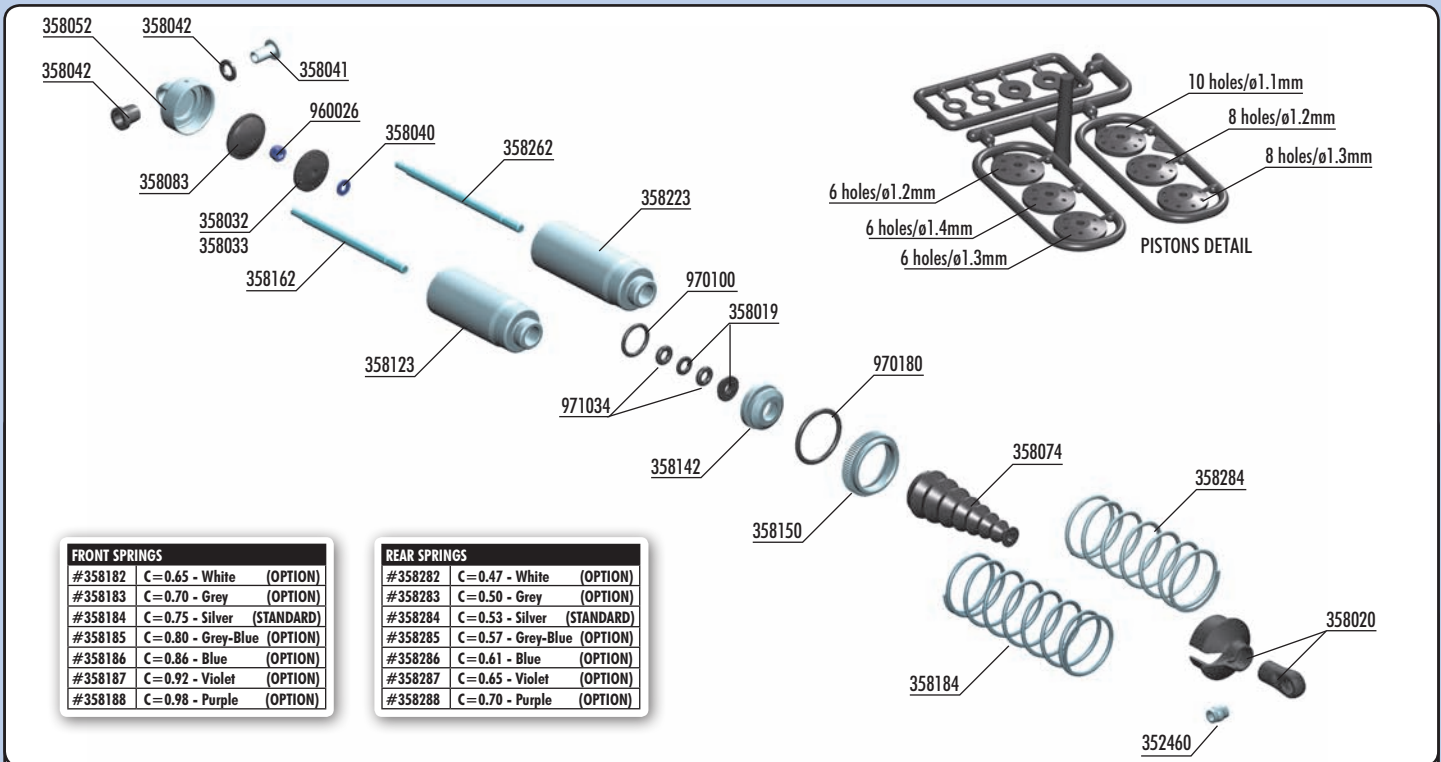

FRONT SPRINGS		
#358182	C=0.65 - White	(OPTION)
#358183	C=0.70 - Grey	(OPTION)
#358184	C=0.75 - Silver	(STANDARD)
#358185	C=0.80 - Grey-Blue	(OPTION)
#358186	C=0.86 - Blue	(OPTION)
#358187	C=0.92 - Violet	(OPTION)
#358188	C=0.98 - Purple	(OPTION)

REAR SPRINGS		
#358282	C=0.47 - White	(OPTION)
#358283	C=0.50 - Grey	(OPTION)
#358284	C=0.53 - Silver	(STANDARD)
#358285	C=0.57 - Grey-Blue	(OPTION)
#358286	C=0.61 - Blue	(OPTION)
#358287	C=0.65 - Violet	(OPTION)
#358288	C=0.70 - Purple	(OPTION)

BAGS



- 35 2460 PIVOT BALL 5.8 - V3 (10)
- 35 8019 XB9 COMPOSITE SET OF SHIMS FOR SHOCKS (2)
- 35 8020 XB9 COMPOSITE SHOCK PARTS
- 35 8032 XB9 SHOCK PISTON SET 8-HOLE (1.2; 1.3) 10-H. (1.1MM)
- 35 8033 XB9 COMPOSITE SHOCK 6-HOLE PISTON SET (1.2; 1.3; 1.4MM)
- 35 8040 HARDENED SHOCK SHIMS (4)
- 35 8041 STEEL SHOCK BUSHING (2)
- 35 8042 COMPOSITE SHOCK BUSHING & SHIM (2+2)
- 35 8052 ALU SHOCK CAP NUT - HARD COATED (2)
- 35 8074 XB9 FOLDING SHOCK BOOT (4)
- 35 8083 SHOCK RUBBER MEMBRANE RIBBED (4)
- 35 8123 XB9 ALU FRONT SHOCK BODY - HARD COATED (2)

- 35 8142 XB9 ALU SHOCK BODY NUT FOR SHOCK BOOT (2)
- 35 8150 ALU SHOCK BODY ADJ. NUT (2)
- 35 8162 XB9 FRONT SHOCK SHAFT (2)
- 35 8184 XRAY FRONT SPRING SET C=0.75 - SILVER (2)
- 35 8223 XB9 ALU REAR SHOCK BODY - HARD COATED (2)
- 35 8262 XB9 REAR SHOCK SHAFT (2)
- 35 8284 XRAY REAR SPRING SET C=0.53 - SILVER (2)
- 96 0026 NUT M2.5 - SHORT (10)
- 97 0100 O-RING 10 x 1.5 (10)
- 97 0180 O-RING 18 x 1.8 (10)
- 97 1034 SILICONE O-RING 3.5x2 (10)



960026
N M2.5



358040
S 2.5x6x0.5



971034
O 3.4x2



970100
O 10x1.5

NOTE
ORIENTATION

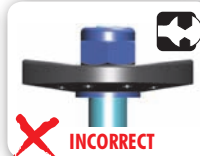
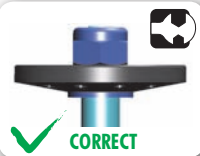
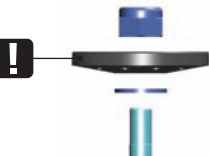

TIGHTEN GENTLY

DO NOT OVERTIGHTEN

2x

8 holes
ø1.2mm
pistons

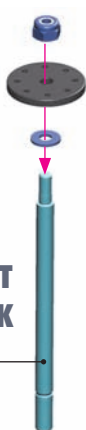

FRONT SHOCK

(SHORT)

2x

8 holes
ø1.3mm
pistons



REAR SHOCK

(LONG)

The self-locking nut is gently tightened. The piston remains undistorted and fits inside the shock body perfectly, ensuring smooth movement of the piston.

The self-locking nut is overtightened, causing distortion of the piston. This will negatively affect the free movement of the piston in the shock body.



Grip the shock rod at top of exposed threads with side cutting pliers. Be careful not to damage the shock rod.



INCORRECT



INCORRECT

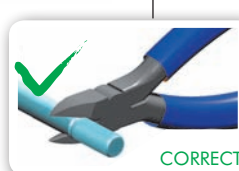

CORRECT

2x FRONT SHOCKS (SHORT)

2x REAR SHOCKS (LONG)

There are two different thickness shims, use them as shown. Use the same procedure when building both front and rear shocks.

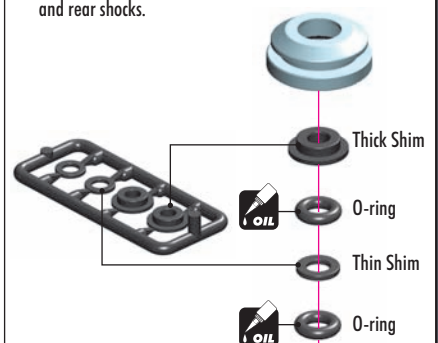

DETAIL

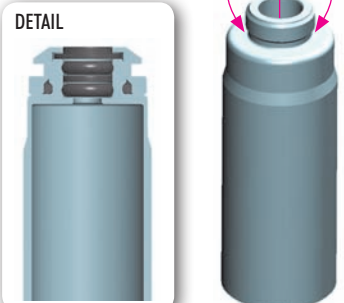

SET-UP BOOK

SHOCK DAMPING
SHOCK PISTONS

SHOCK ABSORBERS



970180
O 18x1.8

2x FRONT SHOCKS

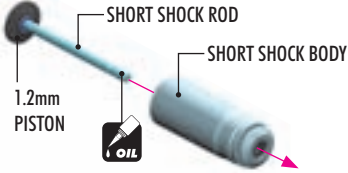

2x REAR SHOCKS

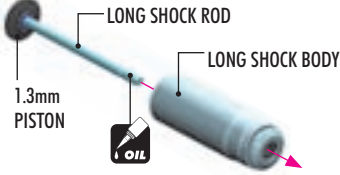

EXTREMELY IMPORTANT

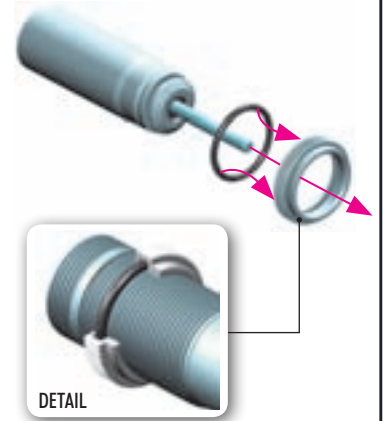
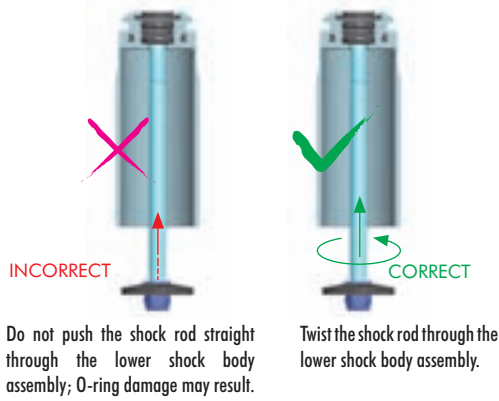

DETAIL

2x FRONT SHOCKS

2x REAR SHOCKS



INCORRECT



INCORRECT

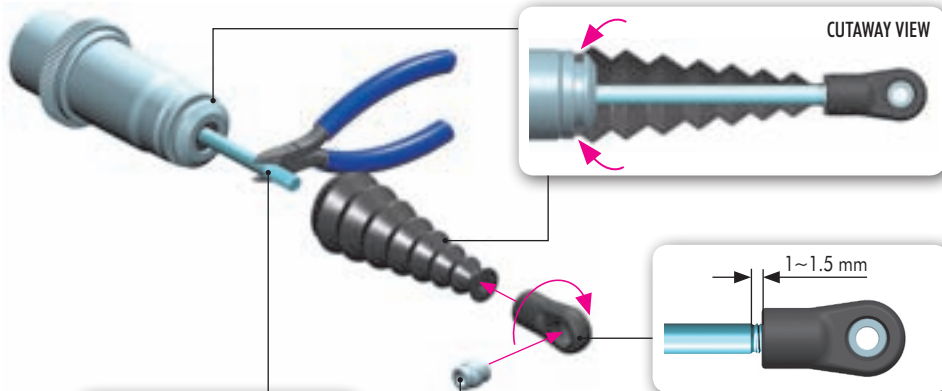

Grip the shock rod at top of exposed threads with side cutting pliers. Be careful not to damage the shock rod.

TIP Follow the TECH TIP on page 5 to install the pivot balls

DEFAULT SHOCK REBOUND SETTING 0% (LOW REBOUND)

Follow the steps below to set the shock rebound to the default setting of 0%.

2x FRONT (SHORT)

Oil 500cSt

2x REAR (LONG)

Oil 600cSt

SET-UP BOOK
SHOCK OIL



1 Extend the shock shaft completely. Fill the shock body with the shock oil. For the FRONT shocks (short) use 500cSt oil. For the REAR shocks (long) use 600cSt oil.



2 Move the shock shaft up and down a few times to release the air bubbles trapped beneath the piston.



3 Orient the filled shock vertically for several minutes with the shock shaft fully extended. The remaining air bubbles will release.



4 Install the shock membrane into the groove in the upper shock cap.



5 Gently place the shock cap assembly onto the filled shock body. Excess oil will spill from the shock. Screw the shock cap onto the body by only a few turns.



6 Gently push the shock shaft completely into the shock body. Excess oil will flow through the hole in the shock cap.



7 Keep the shock shaft pushed in the shock body and tighten the shock cap completely. The rebound will be at approximately 0%.

2x REAR SHOCKS

2x FRONT SHOCKS

LONG REAR SHOCKS

SHORT FRONT SHOCKS

LONG SPRING

SHORT SPRING

FRONT SHOCK PRELOAD
approx. 5mm

REAR SHOCK PRELOAD
0-2mm

SET-UP BOOK
SPRING RATE SELECTION
SHOCK PRELOAD
RIDE HEIGHT

IMPORTANT!
Both rear shocks must be the same overall length.

IMPORTANT!
Both front shocks must be the same overall length.

IMPORTANT!

FRONT & REAR SHOCKS

TIP ALTERNATE SHOCK REBOUND SETTING (50% AND 100%)

The default shock rebound setting is 0% (as described on page 34).

Alternatively, you may set the shock rebound setting to 50% or 100% as described below. Remove the shock springs before performing shock rebound adjustment.

SETTING THE SHOCK REBOUND TO 50% (MEDIUM REBOUND)

1 REMOVE SHOCK CAP

Extend the shock shaft completely and remove the shock cap.

2

Fill the shock body with shock oil up to the top. Make sure to use same viscosity shock oil as is in the shock.

3

Orient the filled shock vertically for several minutes with the shock shaft fully extended. The remaining air bubbles will release.

4 HALF TIGHTEN 50%

Gently place the shock cap assembly onto the filled shock body. Excess oil will spill from the shock.

5

Push the shock shaft 50% into the shock body. Excess oil will bleed through the hole in the shock cap.

6 TIGHTEN FULLY 100%

Keep the shock shaft pushed 50% into the shock body and tighten the shock cap completely. The rebound will be at approximately 50%.

SETTING THE SHOCK REBOUND TO 100% (HIGH REBOUND)

1 REMOVE SHOCK CAP

Extend the shock shaft completely and remove the shock cap.

2

Fill the shock body with shock oil up to the top. Make sure to use same viscosity shock oil as is in the shock.

3

Orient the filled shock vertically for several minutes with the shock shaft fully extended. The remaining air bubbles will release.

4 TIGHTEN FULLY 100%

Gently place the shock cap assembly onto the filled shock body. Keep the shock shaft extended 100% from the shock body and tighten the shock cap completely. The rebound will be at approximately 100%.

12. FINAL ASSEMBLY

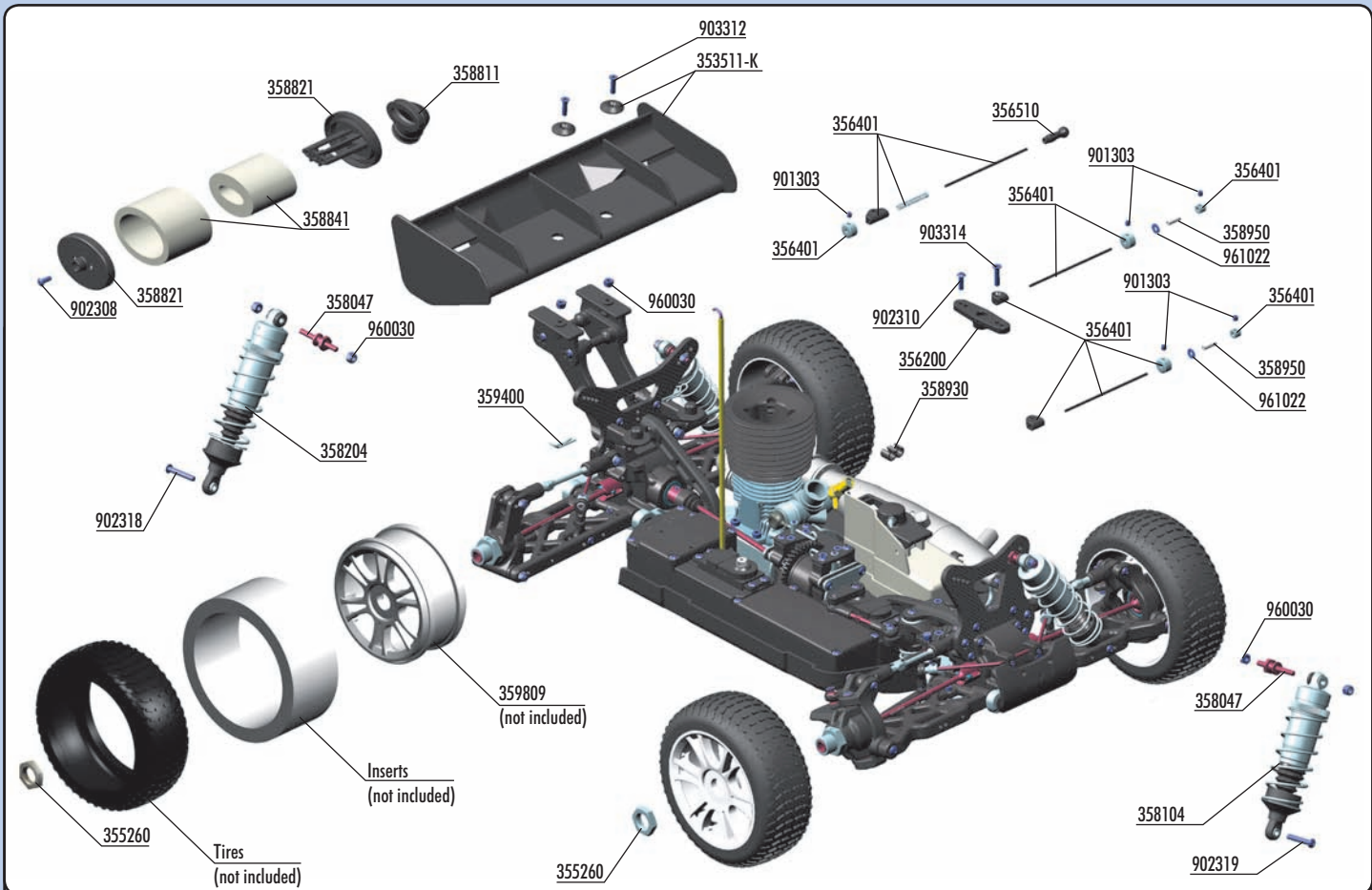

BAG

12

35 3511-K	XB9 REAR WING - BLACK	35 8950	SILICONE TUBING 1M (2.4 x 5.5MM)
35 3511	XB9 REAR WING - WHITE (OPTION)	35 9400	BODY CLIP (10)
35 3511-Y	XB9 REAR WING - YELLOW (OPTION)	35 9707	XRAY XB9 BODY FOR 1/8 OFF ROAD BUGGY
35 5260	WHEEL NUT - HARD COATED (2)	35 9809	WHEELS STARBURST - YELLOW (4) (OPTION)
35 6200	BRAKE/THROTTLE ARMS & SERVO ARMS - SET	90 1303	HEX SCREW SB M3x3 (10)
35 6401	BRAKE/THROTTLE SYSTEM - SET	90 2308	HEX SCREW SH M3x8 (10)
35 6510	CLOSED BALL JOINT 3.9 (4)	90 2310	HEX SCREW SH M3x10 (10)
35 8047	STEEL SCREW SHOCK PIVOT BALL WITH HEX (2)	90 2318	HEX SCREW SH M3x18 (10)
35 8104	XB9 FRONT SHOCK ABSORBERS + BOOTS COMPLETE SET (2)	90 2318	HEX SCREW SH M3x18 (10)
35 8204	XB9 REAR SHOCK ABSORBERS + BOOTS COMPLETE SET (2)	90 2319	HEX SCREW SH M3x18 - LEFT THREAD (10)
35 8811	AIR FILTER ELBOW - LOW PROFILE	90 3312	HEX SCREW SFH M3x12 (10)
35 8821	AIR FILTER BODY & CAP - LOW PROFILE	90 3314	HEX SCREW SFH M3x14 (10)
35 8841	AIR FILTER FOAM & OIL - LOW PROFILE	96 0030	NUT M3 (10)
35 8930	FUEL FILTER MOUNT & TUBING HOLDERS	96 1022	WASHER S 2.2 (10)

- 902318
SH M3x18
- 902319
SH M3x18
LEFT thread
- 960030
N M3

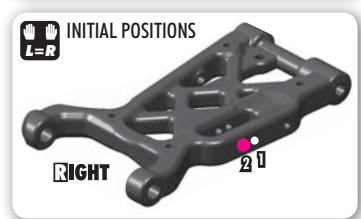
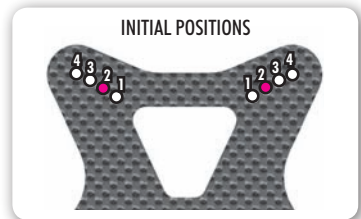
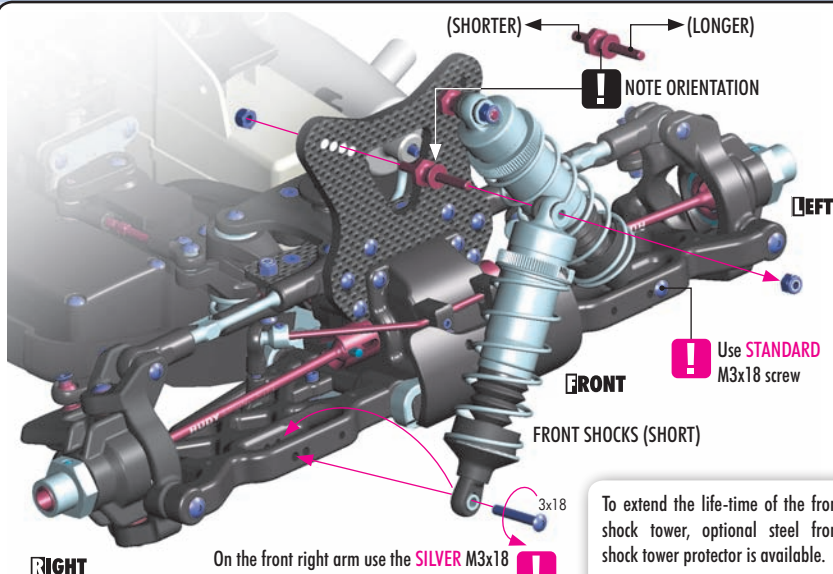

To extend the life-time of the front shock tower, optional steel front shock tower protector is available.

OPTIONAL FRONT SHOCK TOWER STEEL PROTECTOR #352099

SET-UP BOOK
SHOCK ABSORBERS

902318
M3x18





902319
SH M3x18
LEFT thread

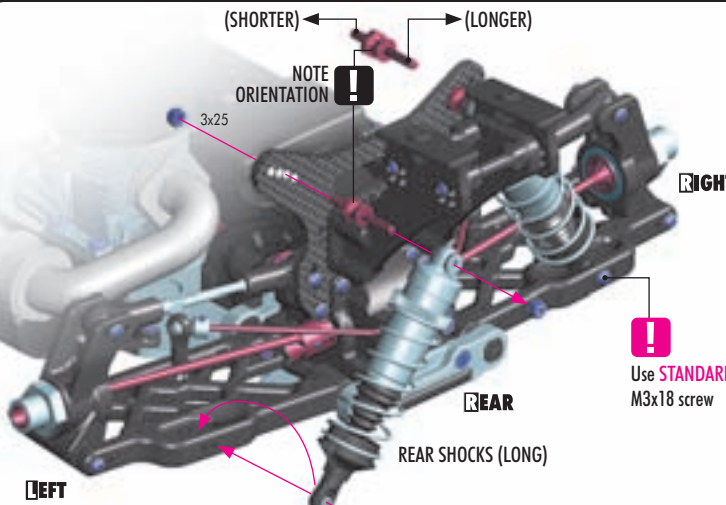

960030
N M3

SET-UP BOOK
SHOCK ABSORBERS



(SHORTER) ← (LONGER)

NOTE ORIENTATION

3x25

RIGHT

REAR

REAR SHOCKS (LONG)

LEFT

3x18

Use **STANDARD** M3x18 screw

On the rear left arm use the **SILVER** M3x18 screw - this screw has **LEFT THREAD**

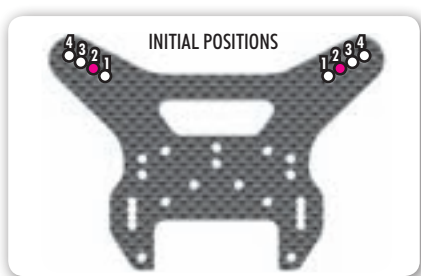

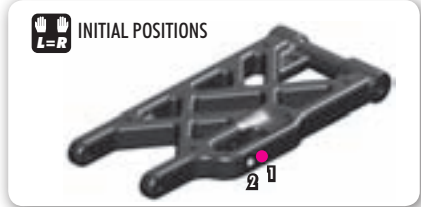

INITIAL POSITIONS



INITIAL POSITIONS

L=R

901303
SB M3x3

902310
SH M3x10



903314
SFH M3x14

Thread brake rods into plastic pivots until flush with outer end

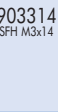
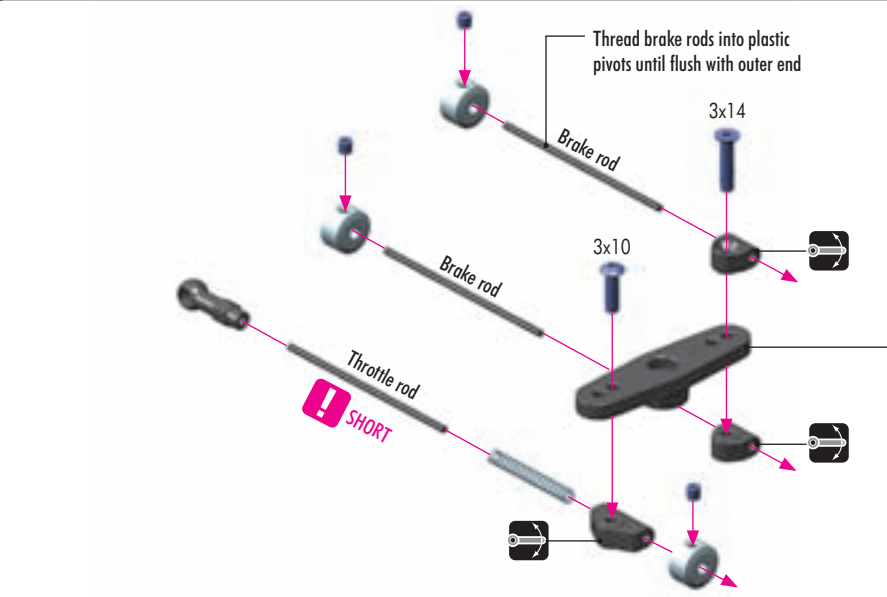
Brake rod

3x14

3x10

Throttle rod

SHORT

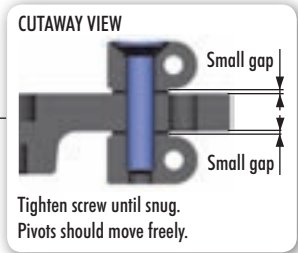

CUTAWAY VIEW

Small gap

Small gap

Tighten screw until snug. Pivots should move freely.

961022
S 2.2



901303
SB M3x3



Use servo horn to match your servo

K - KO Propo F - Futaba H - Hitec

2x SILICONE TUBING

10mm

Servo screw (not included)

Ensure that the servo is in neutral position before attaching the servo horn.

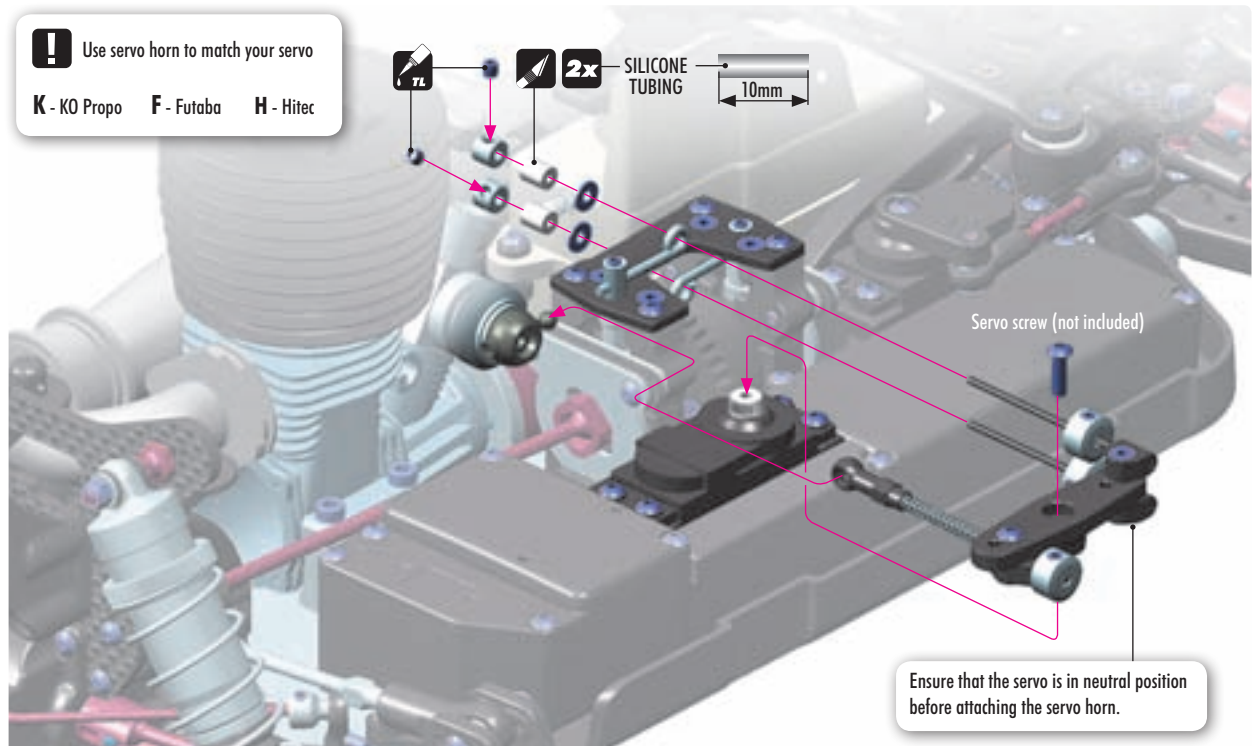

FINAL ASSEMBLY



903312
SFH M3x12



960030
N M3

NOTE
ORIENTATION

DETAIL

XRAY STARBURST WHEELS

#359808	Pink	(OPTION)
#359809	Yellow	(OPTION)

TIP 4x

To tighten the setscrew you can also use the HUDY 17mm Wheel Nut Tool #107570



902308
SH M3x8

Apply air filter oil and follow the engine instructions to service the air filter.

OPTIONAL
AIR FILTER COVER
#358832

Cut the silicone tube depending on engine and muffler. Use the plastic clips to hold the tubes together.

SILICONE TUBE MARKED AS GREEN = FROM FUEL TANK TO CARBURETOR

SILICONE TUBE MARKED AS RED = FROM MUFFLER TO FUEL TANK (TOP)

! Keep fuel line away from clutchbell and flywheel.

To keep the fuel tubes together, use tubing holders.

THROTTLE LINKAGE ADJUSTMENT

NEUTRAL (IDLE)

ADJUST INDIVIDUAL LINKAGES SEPARATELY TO AVOID INTERFERING WITH THE OPERATION OF THE OTHERS

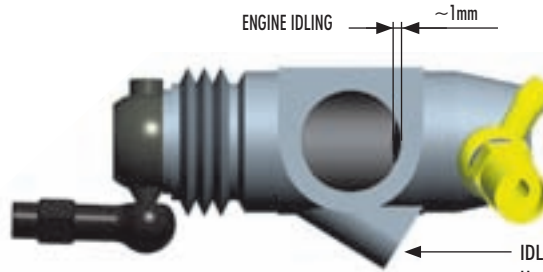
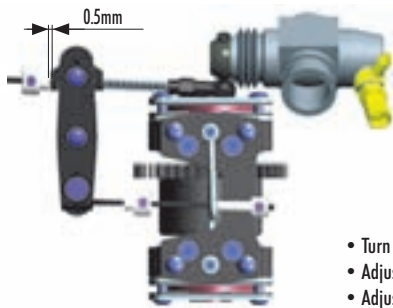

- Turn on the transmitter and receiver and set the engine control servo trim to the neutral position.
- Adjust the idle adjustment screw on the carburetor to open approx. 1mm.
- Adjust both the throttle linkage and brake linkages accordingly.
- DO NOT adjust the linkage with the engine running.

IDLING ADJUSTMENT SCREW.
Use to adjust the idle setting of the carburetor. Do not allow carburetor to close to less than 1mm.

FULL THROTTLE

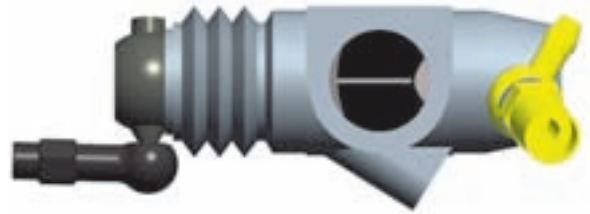

- Adjust the servo-horn mounting position for the carburetor to open fully.
- Change the pivot mounting position on the servo horn in case the carburetor is not opening fully or if it is opening excessively. Or if available on the transmitter, adjust the throttle high end point.

BRAKE



BRAKE ADJUSTING KNOBS:
Upper linkage - rear brake
Lower linkage - front brake

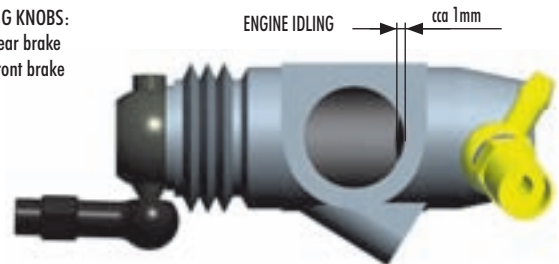

- Adjust the adjustable collars so the brakes work smoothly.
- If the brakes apply too much or not enough, adjust the adjustable collars accordingly. Or if available on the transmitter, adjust the brake endpoint.
- To tighten brakes, turn collar to thread brake rod INTO pivot.
- To loosen brakes, turn collar to thread brake rod OUT of pivot.

- 1 Before cutting and making holes on the body, put the unpainted body on the chassis to confirm the mounting position and location for holes and cutouts.
- 2 Before painting, wash the inside of the body with mild detergent, and then rinse and dry thoroughly.
- 3 Mask all windows.
- 4 Apply paint masks as appropriate.

- 5 Paint the body using paints formulated for polycarbonate bodies.
- 6 When the paint is dry, remove the masking.
- 7 Carefully cut out the body using appropriate scissors or cutting tools.
- 8 When you have finished cutting, peel off the external protective films.

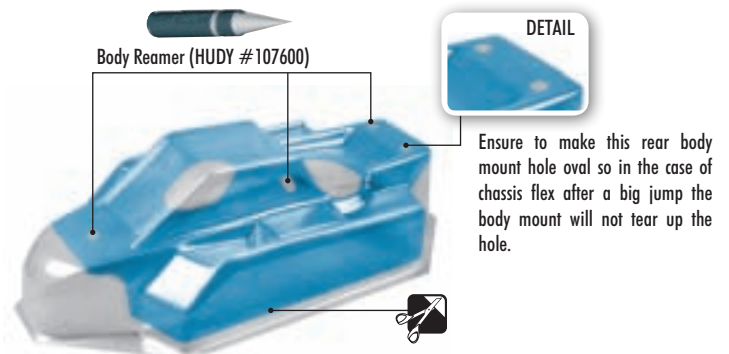
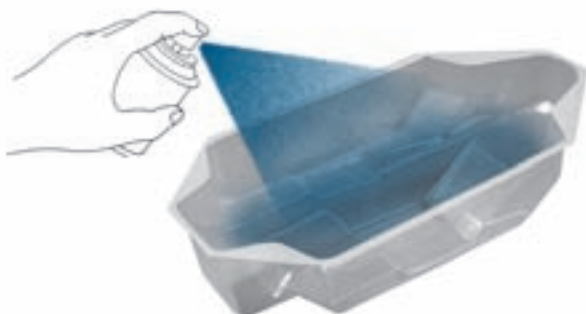

XB9 offers revolutionary flex setting possibilities. Depending on the traction, surface, track layout, you can change the flex setting as you need. XB9 has 3 main Multi-Flex™ settings: soft, medium, stiff

SOFT

Use soft setting for low-traction, dusty tracks. The car will create a lot of traction with this setting but will have less steering and response compared to stiffer setting.

- Screw used
- Screw not used

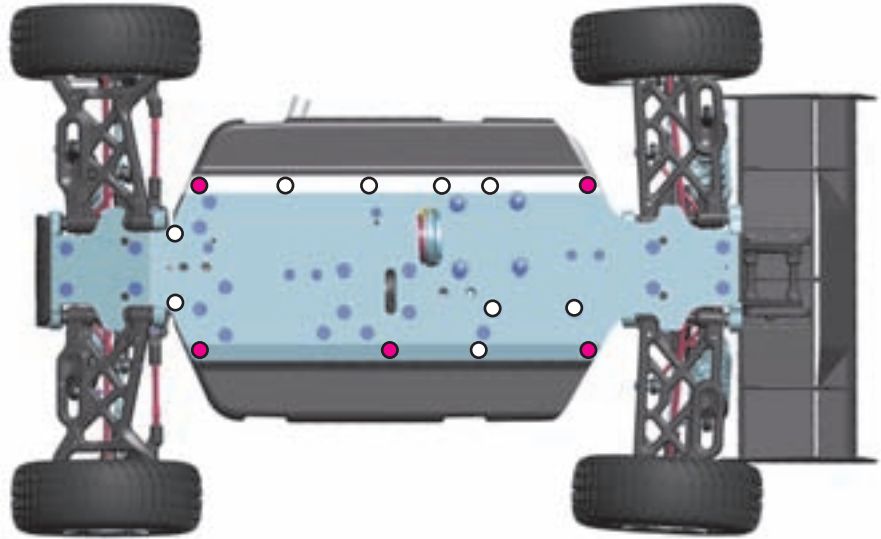

MEDIUM

Use medium setting for medium-traction tracks. This setting offers good balance between steering responsiveness and traction.

- Screw used
- Screw not used

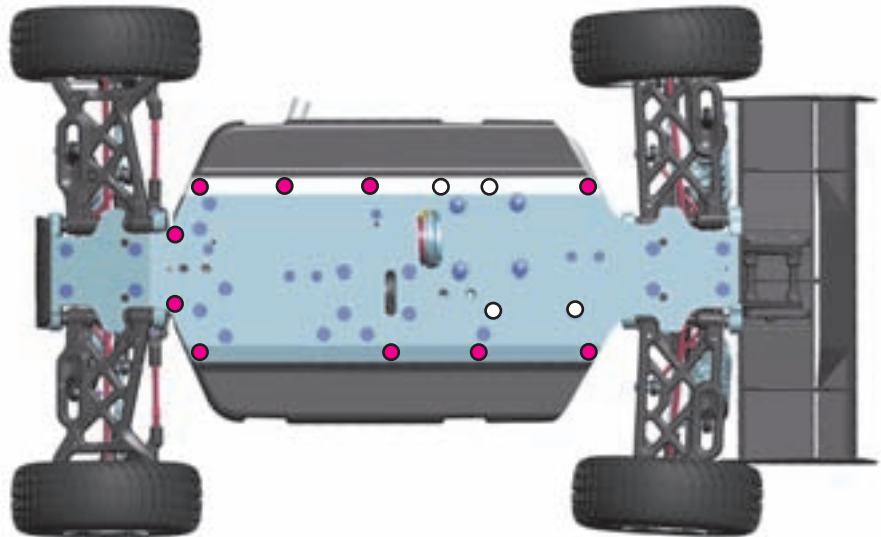

STIFF

Use stiff setting for high-traction tracks where a lot of steering and car response is required.

- Screw used
- Screw not used

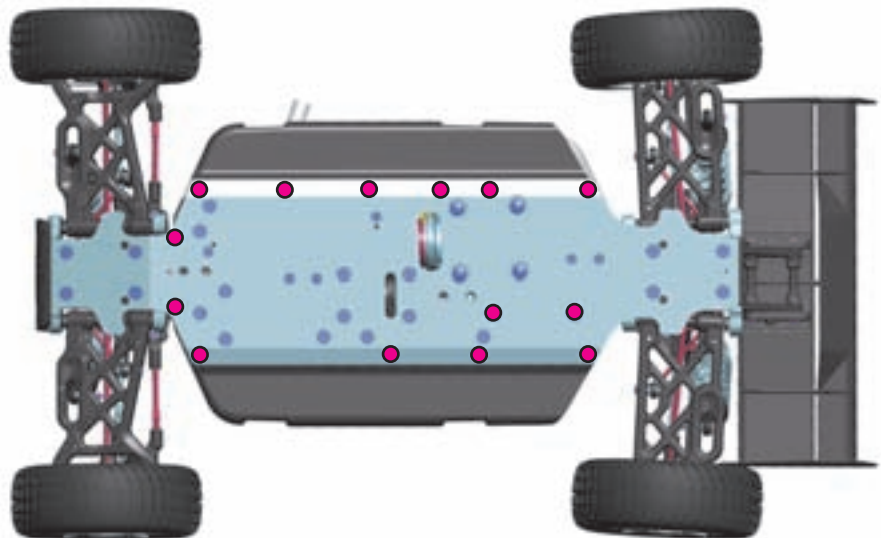

ENGINE OPERATION

PREPARING TO OPERATE THE ENGINE

- Never modify the engine or muffler.
- Confirm the position of needle and idling before running. Be sure to run a new engine smoothly.
- Make sure the air filter is clean and oiled.
- Never run your engine without an air filter. Your engine can be seriously damaged if dirt and debris get inside the engine.
- For proper engine break-in, please refer to the manual that came with the engine.
- The engine may not start or run properly if the air filter is dirty, or choked with sand and dust.
- If the fuel pipe is choked or deteriorates, the engine may not start, and there is danger that fuel will leak out.

STARTING AND RUNNING THE ENGINE

Be sure to observe the following starting process. Failure to do so may cause the model car to start suddenly, which may lead to damage or unexpected accidents.

1. Make sure the transmitter and receiver batteries are fully charged.
2. Make sure that your transmitter and receiver are both on the same frequency. If you have a transmitter with multiple model memory, make sure you have selected the proper profile for your car.
3. Put the car on the starter box and keep the tires from touching the ground.
4. Turn on the transmitter.
5. Turn on the receiver in the car.
6. Make sure the steering servo and engine servos work normally and adjust them correctly.
7. Put fuel in the fuel tank, and close the cap securely.
8. Apply the glow igniter to the engine glowplug.
9. Push the model car onto the starter box to start the engine. (If the engine is new, follow the instruction manual and be sure to break in the new engine properly).
10. When the engine has started, remove the glow igniter.
11. Follow your engine break-in procedure and tune the engine as appropriate.

STOPPING THE ENGINE

Before you stop the engine, try to make sure the engine is at idle first. There are several ways to stop the engine:

- Use a rag to cover the exhaust tip. Be careful! The exhaust is extremely hot so use a thick rag and gloves.
- Pinch the fuel tubing to stop the flow of fuel to the carb. Be careful, this can make the motor run lean which can damage the motor.
- Put your hand over the air filter, or squeeze the air filter element to block the airflow.
- Press an object (such as a screwdriver handle or shoe) against the rotating flywheel to stop its rotation. Be very careful, and do not stick your hand or fingers near the rotating flywheel.

FINISHING OPERATIONS

1. Stop the engine.
2. Turn off the receiver in the car
3. Turn off the transmitter.

MAINTENANCE AFTER RUNNING

Take proper care of your car after running to keep it performing well, and take notice of any damage and wear.

1. Do not leave fuel in the tank.
2. Go outside to drain any residual fuel from the exhaust pipe.
3. Clean the car and remove all sand, mud, and other debris.
4. Use after-run oil in your engine after you have finished running for the day.

SHOCK MAINTENANCE

The most important maintenance task for keeping consistent shock performance is refilling and bleeding them correctly. If built correctly, it will not be necessary to re-build them often. Replacing warped/hard rubber bladders and o-rings, scarred piston rods, or shaved/split/loose composite upper and lower ball joints are also important.

- For club racing, it is recommended to check the shocks for air inside before each race and only re-fill and bleed them if necessary. Before each race day, make sure you take the spring off of each shock, hold it up to your ear, and quickly compress the shock rod fully into the body while listening for any air making a "whistling" or "squishy" sound as it passes through the piston holes. If you hear any air, refill and bleed your shocks. For high-competition racing, it is recommended that the shocks be re-filled and bled before a large event.
- If building or pairing new shocks, always make sure they are the same length using a shock length measuring tool and adjust the lower ball joints as needed.
- If installing new rubber bladders, carefully trim the thin excess rubber from the edges of their lips. Curved body scissors work the best.
- Regularly inspect the amount of dirt on the felt protector in the shocks (if present) and regularly replace with a new one.
- During regular shock operation, oil naturally gets on the shock shaft and drop-by-drop slightly gets out of the shock body. Shocks should be inspected regularly after each race, and oil replaced as required.

BEARING MAINTENANCE

Ball-bearings in an off-road car or truggy must be properly maintained for smooth operation and long lifespan.

Typically, the ball-bearings included in new cars are greased for highest lifespan and as such the drivetrain may not seem to be as free as with lightly-oiled ball-bearings. However, when the car is run the ball-bearings will become more free and the drivetrain will become very efficient.

There are several types of bearings discussed here: bearings which already come greased from the factory, bearings which must be lubricated using the HUDY Bearing Grease, and then there are also bearings in the steering system which need to be lubricated with HUDY Bearing Oil.

The following procedures are recommended to clean all of the bearings in your off-road car or truggy. For high-competition racing, we recommended doing this every 3-4 weeks, or before a major race.

1. Remove the seals on both sides of the bearing (if present). If the seals bend a little and you can see a kink, carefully flatten the kink out by hand.
2. Spray the seals with motor cleaner and blow dry with compressed air.
3. Spray the bearing on both sides with motor cleaner.
4. Spin the bearing while it is still wet to dislodge any particles with the cleaner.
5. Spray the bearing on both sides again.
6. Blow both sides of the bearing dry with compressed air to make sure particles come out.
7. Hold the inner part of the bearing with my left thumb/forefinger and spin it to make sure it spins free without any abnormal vibrations or sounds.
8. Place one drop of bearing oil into each side of the bearing.
9. Replace both seals at the same time by lining them up on each side of the bearing and lightly pressing them in all the way around the bearings circumference with your thumb and forefinger. Do not press too hard or use any type of tool, such as a wrench tip, to push the blue seals in as they will push in too far, bend and cause drag.

If you spin test the bearing after you have re-oiled and sealed it, it will not spin freely for an extended period of time. The lightest of oils may allow it to spin for 1-2 seconds. This is normal and once you have mounted the bearings in the car again, the drive train will spin freely.

Make sure you use a motor cleaner that does not leave a residue after it dries as this may cause drag and wear in the bearings.

CLUTCH BEARINGS

To prolong the lifespan of the clutch bearings, they must be regularly cleaned and lubricated (preferably after each run) using a high-quality grease such as HUDY Bearing Grease. However, after some time the clutch bearings must be replaced with new ones.

RECOMMENDED PRODUCTS

- Use HUDY Bearing Grease to regularly lubricate grease-bearing ball-bearings.
- Use HUDY Bearing Oil to lubricate the bearings of the steering system.
- Use HUDY Bearing Grease to regularly lubricate the clutch bearings.

HUDY #106220



HUDY #106222



HUDY #106221



HUDY #106230



SUSPENSION & DRIVETRAIN MAINTENANCE

- Check suspension for free movement during building and operation, and especially after running and if you have crashed the car. If the suspension does not move freely, use the appropriate HUDY Arm Reamer to clean and resize the holes of the suspension arms.
- Regularly check the drive shaft pins (both side and center) and if they show any wear must be immediately replaced by new pins. If the car is run with worn pins, excessive wear on the diff outdrives will result. The 106000 HUDY Drive Pin Replacement Tool (for 3mm Pins) is a compact, rugged multi-use tool set for replacing 3mm drive pins in drive shafts. Use the HUDY replacement drive shaft pins 3x14 (#106050).
- Regularly inspect and replace the connecting pins which connect the center drive shafts with the pinion gear, and also the pins that connect the wheel drive shafts with wheel axles. Use HUDY Graphite Grease to lubricate the drive shaft connecting joints and the diff gears.
- Pivot balls and ball-joints will naturally wear for some time and will generate play. If there is too much play the pivot balls and ball joints need to be replaced.
- If the car is run in wet conditions, apply WD-40® on all drivetrain parts before the run. After the run, clean and dry the parts again.

HUDY #106210



HUDY SPRING STEEL™

The HUDY Spring Steel™ used in the car is the strongest and most durable steel material on the RC market. While items made from HUDY Spring Steel™ are still subject to wear, the lifespan is considerably longer than any other material. As parts made from HUDY Spring Steel™ wear, the brown color will after some time “go down” but it will not affect the strength of the material. The brown color is only a surface treatment and if the brown color will wear the durability of the part will be still strong.

TROUBLESHOOTING GUIDE

PROBLEM	CAUSE	SOLUTION
ENGINE DOES NOT START	<ul style="list-style-type: none"> • Fuel tank is empty or carburetor is not primed • Bad glowplug or dead glowdriver battery • Fuel lines, fuel filter, air cleaner, or muffler is clogged • Engine is flooded due to over-priming • Carburetor is not adjusted properly • Throttle servo linkage not adjusted properly 	<ul style="list-style-type: none"> • Fill fuel tank with fuel and prime • Replace glowplug or recharge/replace glowdriver battery • Clean or replace clogged part(s) • Remove glowplug, turn car over to discharge fuel from cylinder. Test glowplug and replace if defective • Set idle and main/slow needle adjusting screw to standard starting position • Move throttle servo to neutral position and re-adjust linkage(s)
ENGINE STARTS BUT THEN STALLS	<ul style="list-style-type: none"> • Fuel tank is empty • Fuel lines, fuel filter, air cleaner, or muffler is clogged • Carburetor is not adjusted properly • Engine has overheated 	<ul style="list-style-type: none"> • Fill fuel tank with fuel • Clean or replace clogged part(s) • Re-adjust idle and main/slow needle adjusting screw • Allow engine to thoroughly cool down and open main needle adjusting screw 30° turn richer (CCW)
BAD REACTION AND RESPONSE FROM ENGINE	<ul style="list-style-type: none"> • Carburetor is not adjusted properly • Fuel lines, fuel filter, air cleaner, or muffler is clogged • Low fuel pressure from muffler 	<ul style="list-style-type: none"> • Re-adjust main/slow needle adjusting screw • Clean or replace clogged part(s) • Properly install pressure line between muffler and fuel tank
CAR IS HARD TO CONTROL	<ul style="list-style-type: none"> • Weak transmitter and/or receiver batteries • Low reception from radio antennas • Servo linkages not adjusted properly 	<ul style="list-style-type: none"> • Recharge or replace batteries • Fully extend transmitter and receiver antennas • Move servo to neutral then re-adjust linkage(s)
STEERING DOES NOT WORK PROPERLY	<ul style="list-style-type: none"> • Weak transmitter and/or receiver batteries • Bent linkages or driveshafts • Loose steering components • Drivetrain damage 	<ul style="list-style-type: none"> • Recharge or replace batteries • Check tightness of steering components and tighten if necessary • Replace damaged parts
HANDLING PROBLEMS	<ul style="list-style-type: none"> • Shocks are not working properly • Suspension is binding • Improper tires 	<ul style="list-style-type: none"> • Rebuild the shocks and replace worn or broken parts • Make sure suspension moves freely. Replace worn or broken parts • Use different tires
STEERING FEELS SLUGGISH OR VAGUE	<ul style="list-style-type: none"> • Suspension is binding • Damaged steering servo 	<ul style="list-style-type: none"> • Make sure suspension moves freely, and replace worn or broken parts • Check the steering servo for damage and wear, and replace/repair if necessary
THE CAR DOES NOT DRIVE STRAIGHT	<ul style="list-style-type: none"> • Suspension is binding • Steering trim is off-center • Wheels are loose • Damaged steering servo 	<ul style="list-style-type: none"> • Make sure suspension moves freely, and replace worn or broken parts • Adjust steering trim until car drives straight • Check the make sure the wheel nuts are properly tightened • Check the steering servo for damage and wear, and replace/repair if necessary

SET-UP SHEET

XRAY XB9

RACE	
TRACK	
NAME	
CITY / COUNTRY	
CONTACT	

DATE	
TEMPERATURE / AIR TRACK	
°F or °C	

LAPS	FINAL POSITION	BEST LAP TIME / sec	RACE LENGTH / min.
TRACK SIZE	<input type="checkbox"/> OPEN	<input type="checkbox"/> MEDIUM	<input type="checkbox"/> TIGHT
TRACK TRACTION	<input type="checkbox"/> HIGH	<input type="checkbox"/> MEDIUM	<input type="checkbox"/> LOW
TRACK SURFACE	<input type="checkbox"/> SMOOTH	<input type="checkbox"/> MEDIUM	<input type="checkbox"/> BUMPY
TRACK TYPE	<input type="checkbox"/> HARD PACKED	<input type="checkbox"/> SOFT DIRT	<input type="checkbox"/> CLAY
	<input type="checkbox"/> BLUE GROOVE	<input type="checkbox"/> ASTRO TURF	<input type="checkbox"/> GRASS
TRACK CONDITION	<input type="checkbox"/> DRY	<input type="checkbox"/> DUSTY	<input type="checkbox"/> WET
	<input type="checkbox"/> MUD		

DIFFERENTIALS		
TYPE		
FRONT	CENTER	REAR
DIFFERENTIAL - OIL		

GEARING			
CLUTCH BELL		SPUR GEAR	
	T		T
PINION		CROWN GEAR	
	T		T
SPRING		SHOE	

FRONT	SHOCKS	REAR
#358182 C = 0.65	<input type="checkbox"/> WHITE	#358282 C = 0.47
#358183 C = 0.70	<input type="checkbox"/> GREY	#358283 C = 0.50
#358184 C = 0.75	<input type="checkbox"/> SILVER	#358284 C = 0.53
#358185 C = 0.80	<input type="checkbox"/> GREY-BLUE	#358285 C = 0.57
#358186 C = 0.86	<input type="checkbox"/> BLUE	#358286 C = 0.61
#358187 C = 0.92	<input type="checkbox"/> VIOLET	#358287 C = 0.65
#358188 C = 0.98	<input type="checkbox"/> PURPLE	#358288 C = 0.70
	OTHER	
	OIL / cST	
	REBOUND / %	
<input type="checkbox"/> 6 HOLES	PISTONS	<input type="checkbox"/> 6 HOLES
<input type="checkbox"/> 8 HOLES	1.1mm	<input type="checkbox"/> 8 HOLES
<input type="checkbox"/> 10 HOLES	1.2mm	<input type="checkbox"/> 10 HOLES
	1.3mm	
	1.4mm	
	OTHERS	

FRONT	ANTI ROLL BAR	REAR
	THICKNESS / mm	

FRONT	TIRES	REAR
	TYPE	
	INSERTS	
	WHEELS	

ENGINE	
TYPE	
MANIFOLD	
MUFFLER	
PLUG	
FUEL	

BODY	
TYPE	

COMMENTS

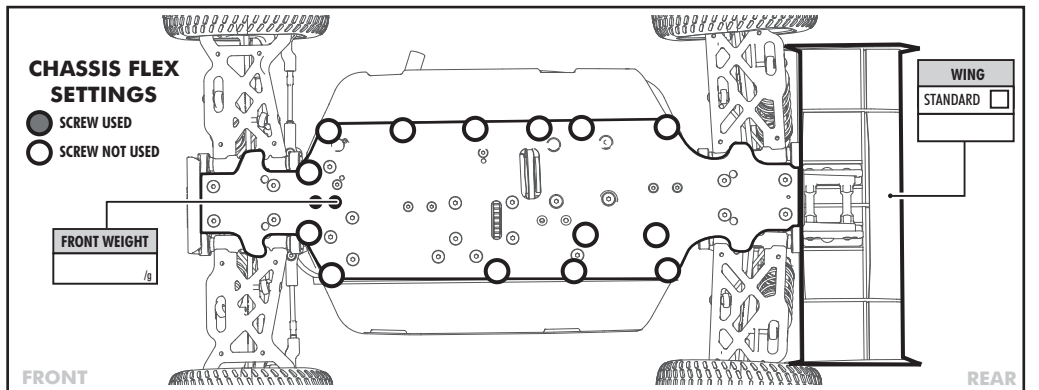
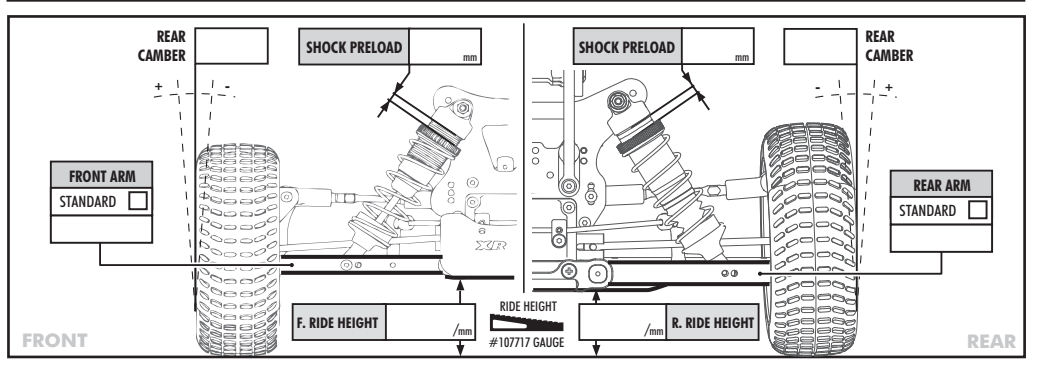
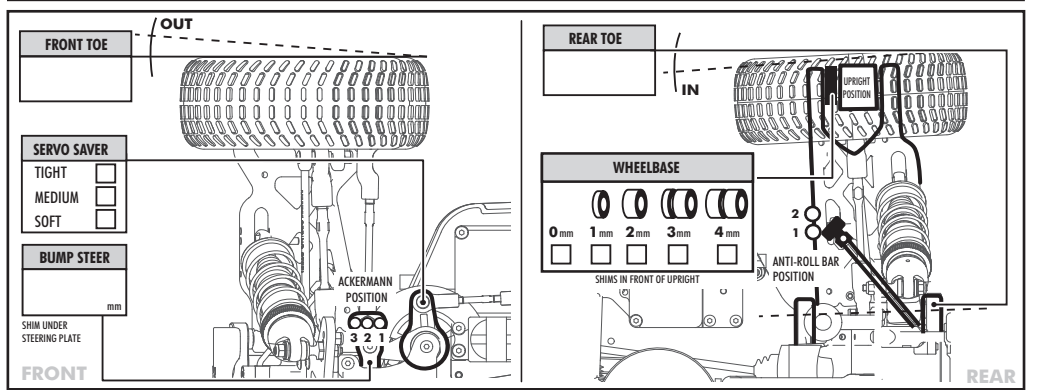
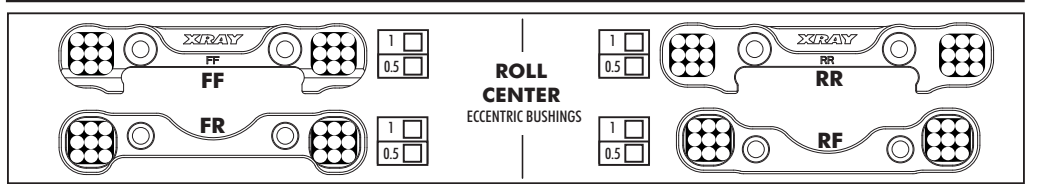
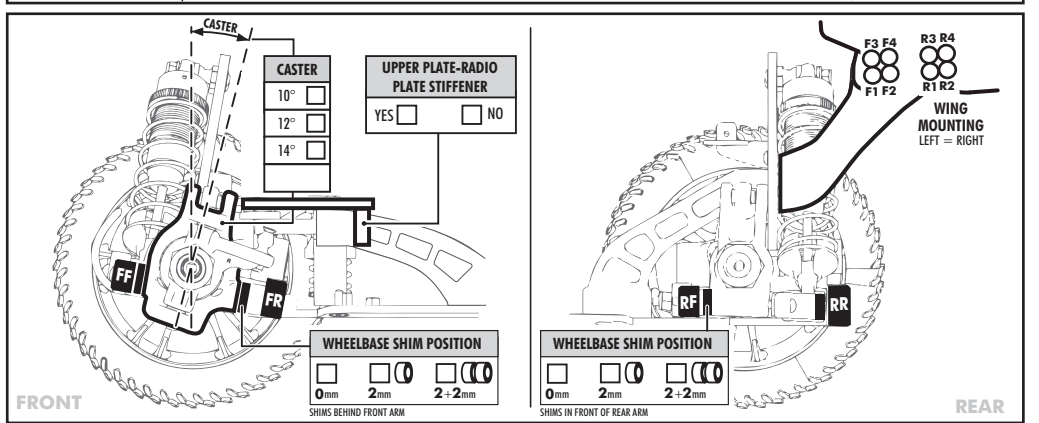
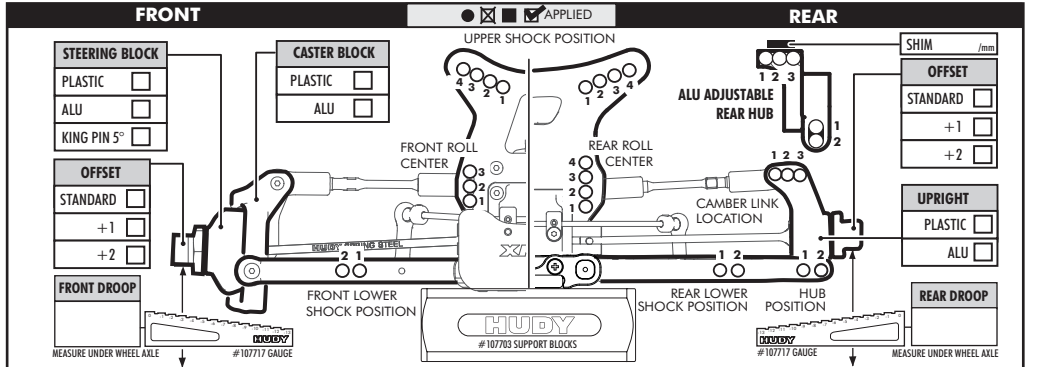

XRAY EUROPE

XRAY, K VÝSTAVISKU 6992, 91101 TRENCIN, SLOVAKIA, EUROPE
PHONE: +421-32-740 11 00, FAX: +421-32-740 11 09, info@teamxray.com

XRAY USA

RC AMERICA, 2970 BLYSTONE LANE, SUITE 109, DALLAS, 75220 TEXAS, USA
PHONE: 214-744-2400, FAX: 214-744-2401, xray@rcamerica.com



www.teamxray.com

www.facebook.com/teamxray www.twitter.com/teamxray www.youtube.com/xrayracing



ALL RIGHTS RESERVED. © XRAY. ALL ARTWORK & DESIGN BY XRAY

